

# MODEL : VOMY

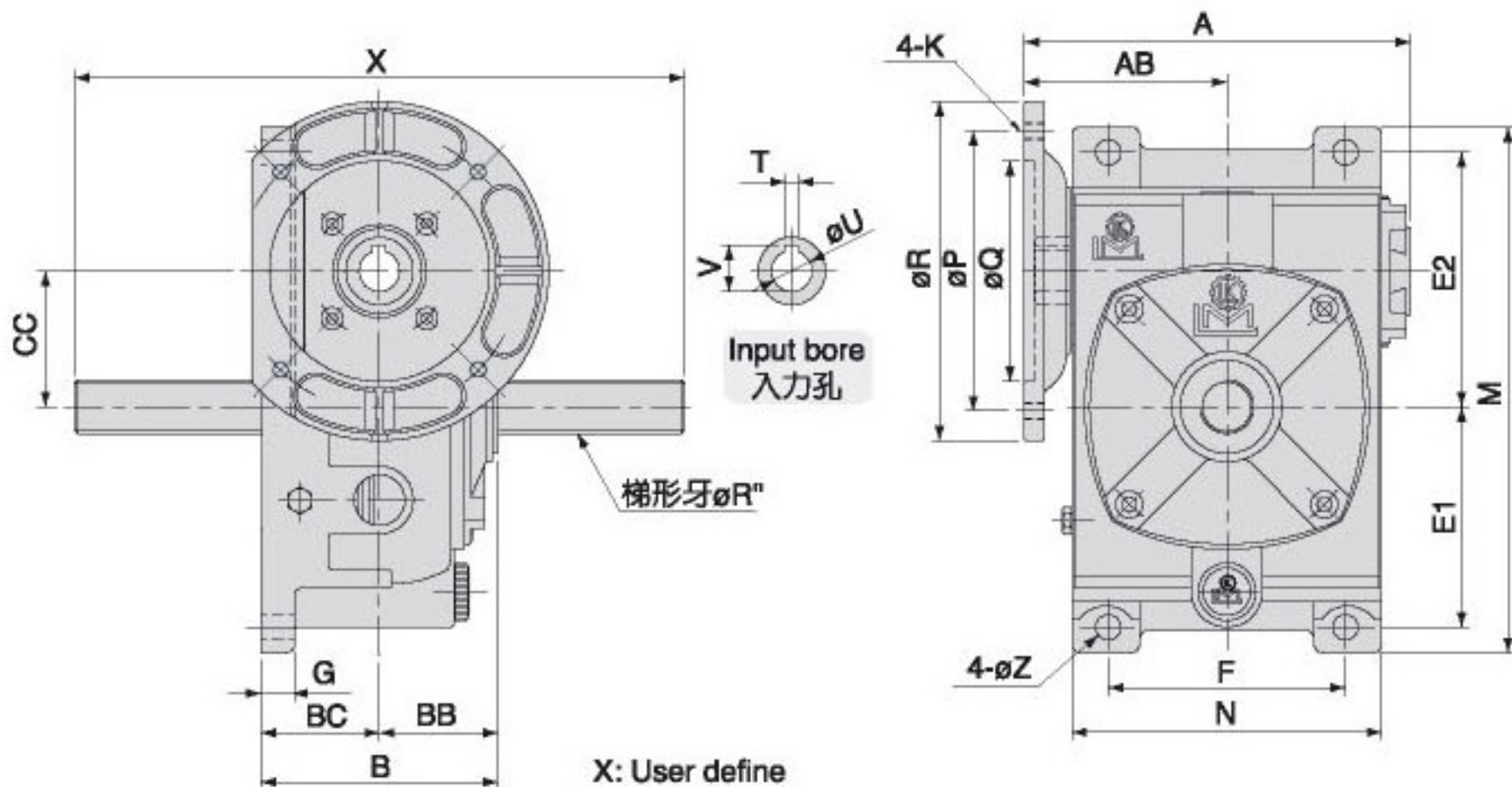

(本公司另有升降器機種，請參考頁次J)  
Please Reference page J for ScrewJack



## 尺寸表 Dimension(m/m)

| 減速比<br>RATIO | 馬力<br>HP    |               | A   | AB  | B   | BB  | BC  | CC  | 馬達盤<br>MOTOR FLANGE |            |            |            | 腳座<br>FOOT STOCK |     |     |     |     | 入力孔<br>INPUT BORE |    |              | 角牙<br>R" | 重量<br>Weight<br>(KG) |        |      |
|--------------|-------------|---------------|-----|-----|-----|-----|-----|-----|---------------------|------------|------------|------------|------------------|-----|-----|-----|-----|-------------------|----|--------------|----------|----------------------|--------|------|
|              | 型號<br>MODEL | 1/10~<br>1/30 |     |     |     |     |     |     | 1/40~<br>1/60       | P          | Q          | R          | K                | E1  | E2  | F   | M   | N                 | G  | Z            |          |                      | V      | T    |
| 50           | 1/4         |               | 154 | 81  | 99  | 49  | 50  | 50  | 130                 | 110        | 160        | M8         | 93               | 102 | 90  | 220 | 118 | 16                | 11 | 12.7         | 4        | 11                   | 1"     | 7.6  |
| 60           | 1/2         | 1/4           | 167 | 87  | 109 | 54  | 55  | 60  | 130                 | 110        | 160        | M8         | 105              | 120 | 100 | 252 | 128 | 18                | 11 | 12.7<br>16.3 | 4<br>5   | 11<br>14             | 1"     | 11.4 |
| 70           | 1           | 1/2           | 200 | 108 | 129 | 64  | 65  | 70  | 130<br>165          | 110<br>130 | 160<br>200 | M8<br>M10  | 120              | 135 | 120 | 288 | 160 | 20                | 15 | 16.3<br>21.8 | 5<br>6   | 14<br>19             | 1 1/8" | 17.6 |
| 80           | 2           | 1             | 226 | 118 | 139 | 69  | 70  | 80  | 165                 | 130        | 200        | M10        | 130              | 150 | 140 | 315 | 183 | 20                | 15 | 21.8<br>27.3 | 6<br>8   | 19<br>24             | 1 1/4" | 23.2 |
| 100          | 3           | 2             | 278 | 144 | 179 | 89  | 90  | 100 | 165<br>215          | 130<br>180 | 200<br>250 | M10<br>M12 | 155              | 180 | 190 | 380 | 230 | 30                | 15 | 27.3<br>31.3 | 8        | 24<br>28             | 1 1/2" | 41.4 |
| 120          | 5           | 3             | 333 | 173 | 199 | 99  | 100 | 120 | 215                 | 180        | 250        | M12        | 185              | 215 | 220 | 450 | 266 | 30                | 18 | 31.3         | 8        | 28                   | 2"     | 65   |
| 135          | 7 1/2       | 5             | 369 | 187 | 219 | 109 | 110 | 135 | 215<br>265          | 180<br>230 | 250<br>300 | M12<br>M12 | 210              | 235 | 260 | 495 | 305 | 35                | 18 | 31.3<br>41.3 | 8<br>10  | 28<br>38             | 2"     | 81   |