

MODEL : VJ

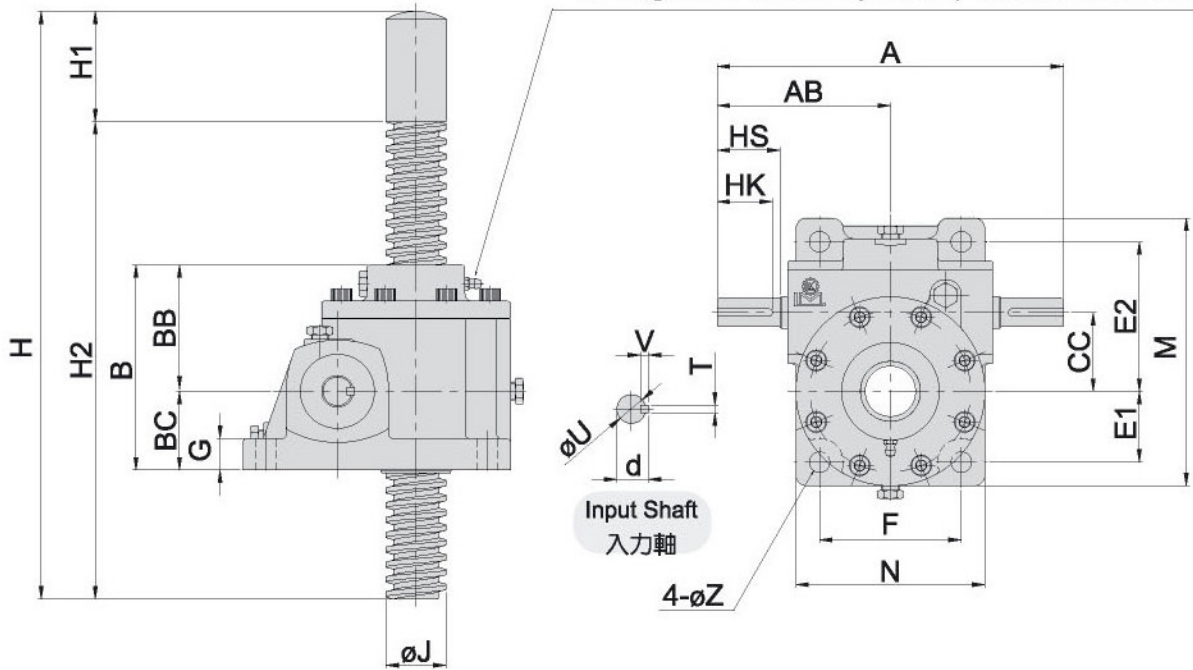

使用前須注入黃油(潤滑螺桿)
To oil grease before operate (lubrication the screw)



註一：請參考螺桿端尺寸表
註二：行程=H-H1-B
Note1: Please refer to dimension of screw end.
Note 2: Route=H-H1-B

尺寸表 Dimension

單位：m/m

型號 MODEL	減速比 RATIO	馬力 HP	A	AB	B	BB	BC	CC	腳座 FOOT STOCK				入力軸 INPUT SHAFT				ØJ 螺桿 SCREW	螺距 PITCH	H1 註一 NOTE1	重量 WEIGHT (KG)			
									E1	E2	F	M	N	G	Z	HS					U	d	TxVxHK
35	5	1/4	170	85	110	70	40	35	38	73	66	135	90	16	11	30	15	17	5x5x25	1"	P=5	50	4.1
	10	1/2																					
	20	1/2																					
40	6	1/4	220	110	130	80	50	40	42	83	80	155	110	18	11	40	18	20	5x5x35	1 1/4"	P=6	60	7.5
	12	1/2																					
50	6	1/2	220	110	130	80	50	50	45	95	90	170	120	20	13	40	18	20	5x5x35	1 1/2"	P=6	70	9
	12	1																					
	24	1																					
60	8	1	278	139	160	100	60	60	70	120	110	230	148	22	17	45	25	28	7x7x40	2"	P=8	70	16
	16	2																					
70	10	1	318	159	180	110	70	70	75	135	140	250	178	25	17	50	28	31	7x7x45	2 1/2"	P=10	80	26
	20	2																					
	40	2																					
80	12	2	360	180	210	130	80	80	90	155	160	295	210	28	21	50	28	31	7x7x45	75mm	P=12	80	45
	18	3																					
	36	3																					