

MODEL : NEOHM

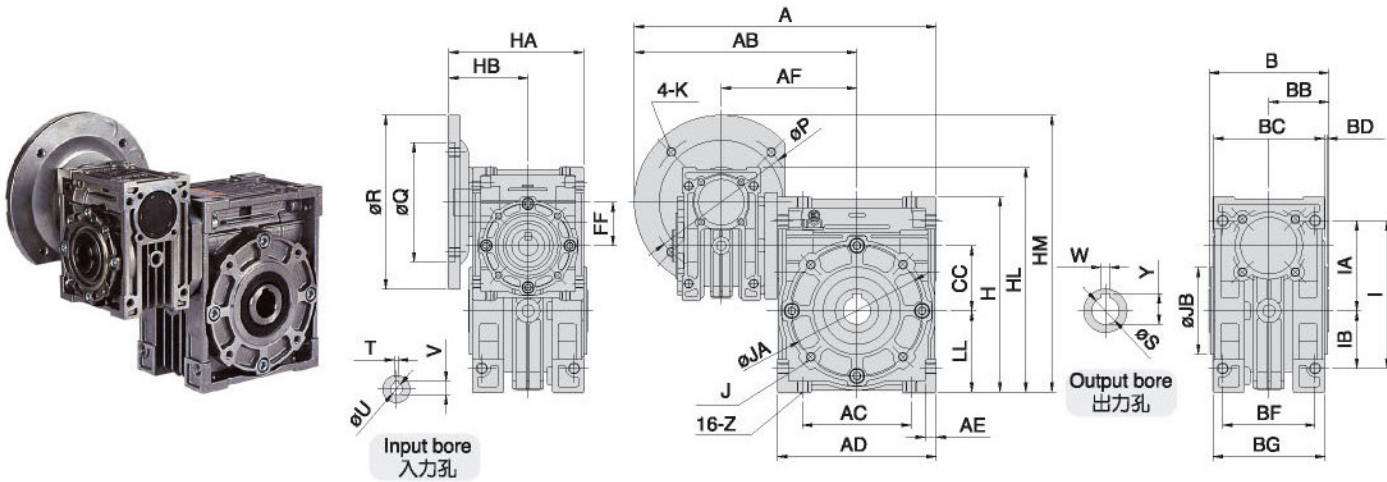

出力段蝸輪箱中心距離(mm)

Distance to the center of output-stage outer shell.

40

50

60

70

入力段蝸輪箱中心距離(mm)

Distance to the center of input-stage outer shell.

30

30

40

50

尺寸表 Dimension

單位 : m/m

型號 MODEL	減速比 RATIO	馬力 HP	CC	FF	A	AB	AC	AD	AE	AF	B	BB	BC	BD	BF	BG	H	HA	HB	HL	HM
40	100~1600	1/8(90W)	40	30	189	138	70	102	7.5	93	90	45	80	2	60	72	122	98	58	148	165
	100-900	1/4(63B)			214	163															190
50	100~2400	1/8(90W)	50	30	207	147	80	120	8.5	102	100	50	94	3	70	85	145	98	58	168	185
	100~1800	1/4(63B)			232	172															210
60	100~2400	1/4	60	40	278	205	100	146	10	125	110	55	102	3	85	103	180	124	73	207	255
	100~1200	1/2																			
70	100~3600	1/4	70	50	310	225	120	170	12	145	130	65	118	3	90	110	200	141	81		285
	100~2500	1/2			310	225												141	81	240	285
	100~1200	1			330	245												148	88	240	305

型號 MODEL	減速比 RATIO	馬力 HP	I	IA	IB	LL	Z	馬達盤及入力孔 MOTOR FLANGE & INPUT BORE							出力孔 OUTPUT BORE						重量 Weight(KG)
								P	Q	R	K	V	T	U	W	S	Y	JA	JB	J	
40	100~1600	1/8(90W)	90	55	35	50	M8	104	83	□90	M6	12.7	4	11	6	20	22.8	77	60	12-M6	3.96
	100-900	1/4(63B)						115	95	140											
50	100~2400	1/8(90W)	105	65	40	60	M10	104	83	□90	M6	12.7	4	11	8	25	28.3	95	70	12-M6	5.51
	100~1800	1/4(63B)						115	95	140											
60	100~2400	1/4	136	83	53	75	M10	130	110	160	M8	12.7	4	11	8	25	28.3	120	80	12-M8	8.7
	100~1200	1/2										16.3	5	14							
70	100~3600	1/4	150	90	60	85	M10	130	110	160	M8	12.7	4	11	8	30	33.3	140	90	12-M10	14.3
	100~2500	1/2						130	110	160		16.3	5	14							
	100~1200	1						165	130	200		M10	21.8	6							