

MODEL : VOW



▲40#~135#



▲155#~175#

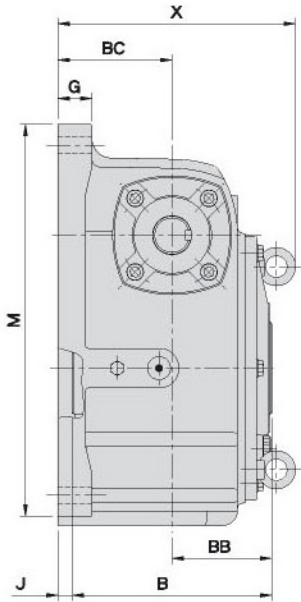
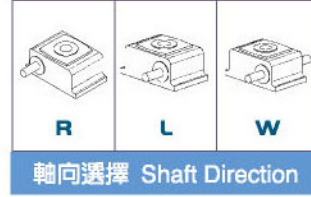

VOW155~175

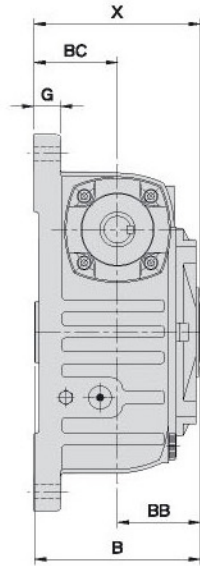

VOW40~135

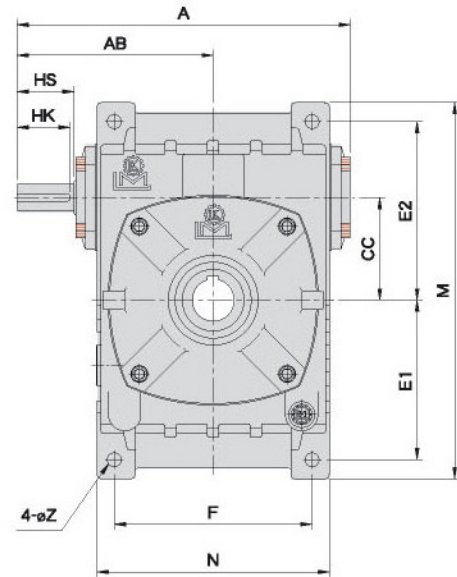
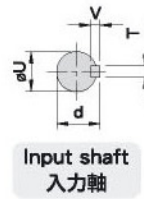
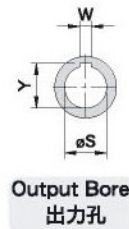

尺寸表 Dimension(m/m)

減速比 RATIO	馬力 HP		A	AB	J	B	X	BB	BC	CC	腳座 FOOT STOCK						入力軸 INPUT SHAFT				出力孔 OUTPUT BORE			重量 Weight (KG)	
	1/10-1/40- 1/30	1/80									E1	E2	F	M	N	G	Z	HS	U	d	TxVxHK	W	Y		S
型號 MODEL	1/10-1/40- 1/30	1/80																							
40	1/8		139.5	86		88	89	44	45	40	75	85	70	183	94	11	9	25	12	13.5	4x4x20	6	22.8	20	5
50	1/4		178	105		98	99	49	50	50	93	102	90	220	118	16	11	30	12	13.5	4x4x25	6	22.8	20	7.8
60	1/2	1/4	198	120		108	109	54	55	60	105	120	100	252	128	18	11	40	15	17	5x5x35	8	28.3	25	12
70	1	1/2	235	140		128	129	64	65	70	120	135	120	288	160	20	15	40	18	20	5x5x35	8	33.3	30	15.4
80	2	1	268	161		138	139	69	70	80	130	150	140	315	183	20	15	50	22	25	7x7x45	10	38.3	35	21.2
100	3	2	322	190		178	179	89	90	100	155	180	190	380	230	26	15	50	25	28	7x7x45	10	43.3	40	39.4
120	5	3	390	231		198	199	99	100	120	185	215	220	450	266	30	18	65	30	33	7x7x60	12	48.3	45	62
135	7 1/2	5	438	258		218	219	109	110	135	210	235	260	495	305	35	18	75	35	38	10x8x70	15	59.3	55	78.8
155	10	7 1/2	491	292	16.5	247	288	123.5	140	155	145	265	290	460	340	45	20	85	40	43	10x8x80	15	69.3	65	104
175	15	10	555	325	19	262	305	131	150	175	167	293	320	516	390	45	22	85	45	48	12x8x80	18	94.3	90	149