

MODEL : VMP

(裝配油壓馬達用) For assembling hydraulic motor

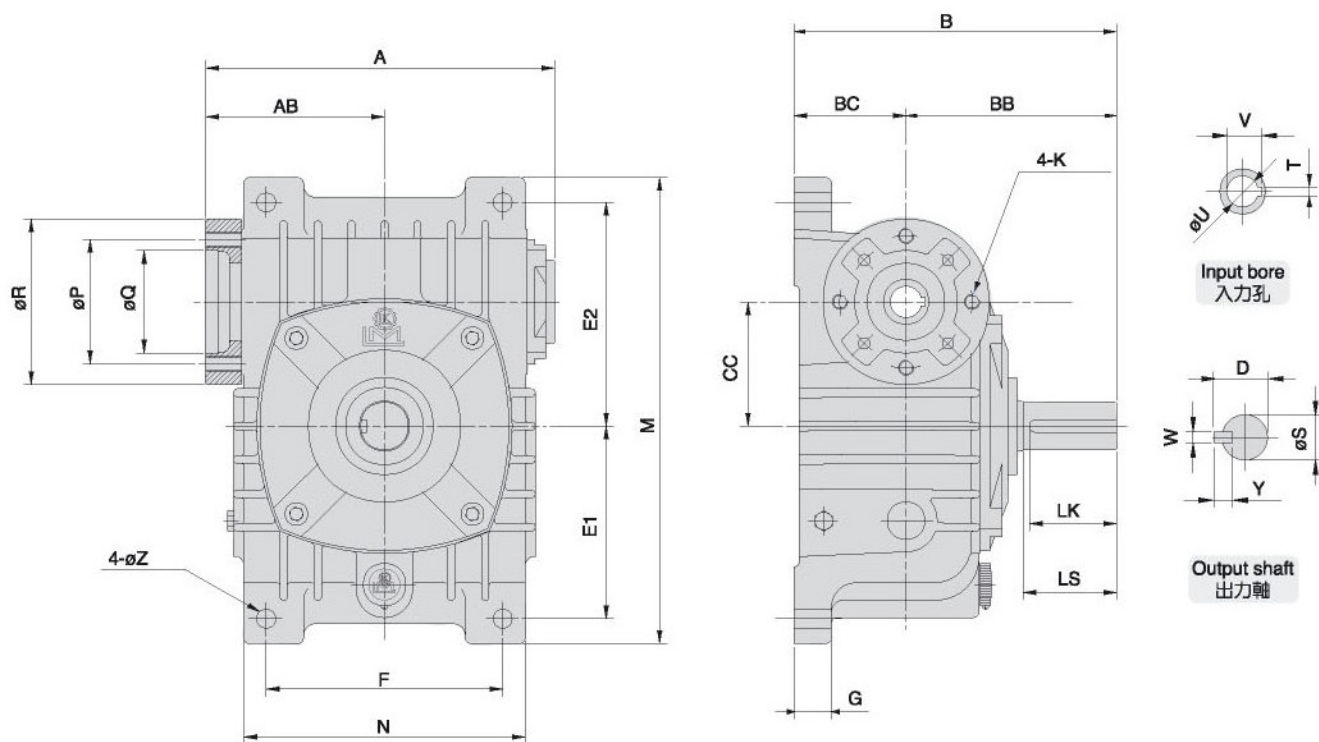
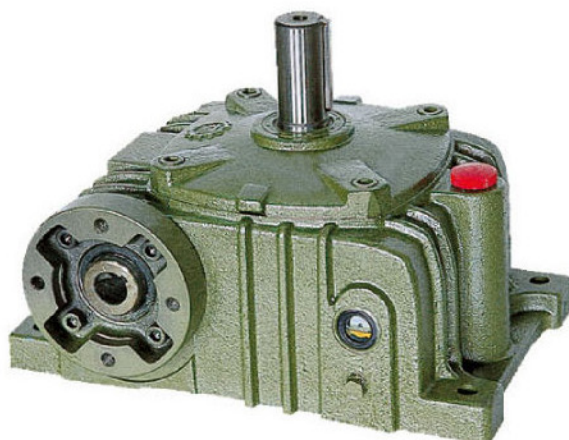

尺寸表 Dimension

單位 : m/m

型號 MODEL	A	AB	B	BB	BC	CC	油壓盤 MOTOR FLANGE				腳座 FOOT STOCK						入力孔 INPUT BORE			出力軸 OUTPUT SHAFT				重量 Weight (KG)	
							P	Q	R	K	E1	E2	F	M	N	G	Z	V	T	U	LS	S	D		WxYxLK
100	278	143.5	260	170	90	100	107	82.55	133	M12	155	180	190	380	230	30	15	28.38	6.35	25.4	75	38	41	10x8x70	41
120	314	155	290	190	100	120	107	82.55	145	M12	185	215	220	452	266	30	18	28.38	6.35	25.4	85	45	48	12x8x80	63.6
135	358	178	324	214	110	135	107	82.55	153	M12	210	235	260	497	306	35	18	28.38	6.35	25.4	95	55	59	15x10x90	84
155	396	197	393	253	140	155	107	82.55	153	M12	145	265	290	464	345	45	20	28.38	6.35	25.4	110	60	64	15x10x105	116.8
175	457	227.5	412	262	150	175	107	82.55	174	M12	167	293	320	520	385	45	20	28.38	6.35	25.4	110	65	69	18x10x105	148.4