

MODEL : UW

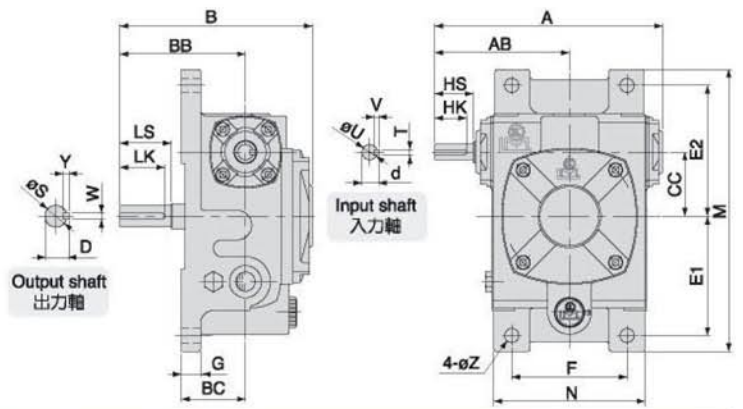

▲40#~135#

▲155#~175#

尺寸表 Dimension(m/m)

減速比 RATIO	馬力 HP	A	AB	B	BB	BC	CC	腳座 FOOT STOCK					入力軸 INPUT SHAFT				出力軸 OUTPUT SHAFT				重量 Weight (KG)		
								E1	E2	F	M	N	G	Z	HS	U	d	TxVxHK	LS	S		D	WxYxLK
型號 MODEL	1/10~1/40~ 1/30 1/60																						
40	1/8	139.5	86	124	80	45	40	75	85	70	182	94	14	9	25	12	13.5	4x4x20	30	15	17	5x5x25	4.5
50	1/4	178	105	148	98	50	50	93	102	90	220	118	16	11	30	12	13.5	4x4x25	40	17	19	5x5x35	6.8
60	1/2	198	120	165	110	55	60	105	120	100	252	128	18	11	40	15	17	5x5x35	50	22	25	7x7x45	9.2
70	1	235	140	195	130	65	70	120	135	120	288	160	20	15	40	18	20	5x5x35	60	28	31	7x7x55	14.4
80	2	268	161	210	140	70	80	130	150	140	315	183	20	15	50	22	25	7x7x45	65	32	35	10x8x60	19.4
100	3	322	190	260	170	90	100	155	180	190	380	230	26	15	50	25	28	7x7x45	75	38	41	10x8x70	38.6
120	5	390	231	290	190	100	120	185	215	220	450	266	30	18	65	30	33	7x7x60	85	45	48	12x8x80	62
135	7 1/2	438	258	324	214	110	135	210	235	260	495	305	35	18	75	35	38	10x8x70	95	55	59	15x10x90	83
155	10	491	292	393	253	140	155	265	290	460	340	45	20	85	40	43	10x8x80	110	60	64	15x10x105	106.8	
175	15	555	325	412	262	150	175	293	320	516	385	45	22	85	45	48	12x8x80	110	65	69	18x10x105	141	

MODEL : UW



▲200#~350#

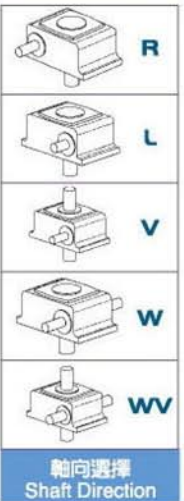
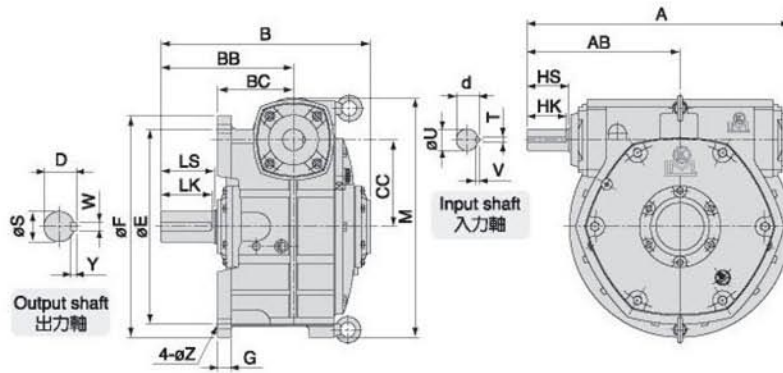

尺寸表 Dimension(m/m)

減速比 RATIO	馬力 HP	A	AB	B	BB	BC	CC	腳座 FOOT STOCK					入力軸 INPUT SHAFT				出力軸 OUTPUT SHAFT				重量 Weight (KG)		
								E	F	M	G	Z	HS	U	d	TxVxHK	LS	S	D	WxYxLK			
型號 MODEL	1/10~1/40~ 1/30 1/60																						
200	20	15	604	352	486	311	175	200	450	510	558	32	22	95	50	53	12x8x90	125	70	75	20x12x120	185.2	
225	25	20	650	375	525	335	190	225	510	580	622	35	27	95	55	59	15x10x90	140	80	85	20x12x135	255.2	
250	30	25	728	422	559	359	200	250	570	640	675	35	27	110	60	64	15x10x105	155	90	96.5	24x16x150	298	
300	40	30	864	498	596	387	235	300	660	750	880	38	8-36	125	70	73	18x10x120	170	95	101	24x16x160	465	
350	50	40	945	570	770	480	290	350	780	880	945	38	8-38	145	80	85	20x12x135	190	115	124	32x20x185	785	