

MODEL : TW

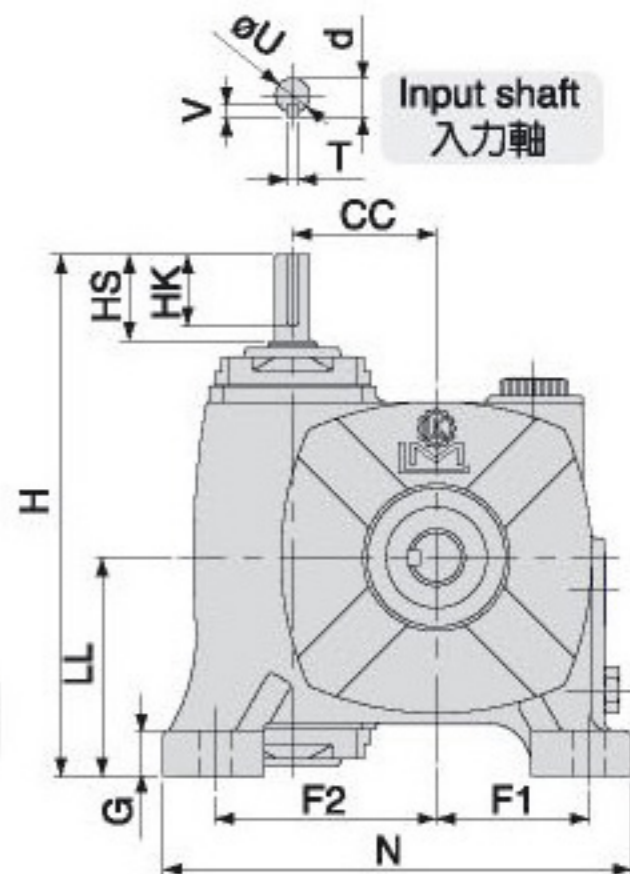
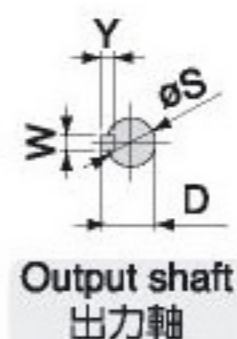
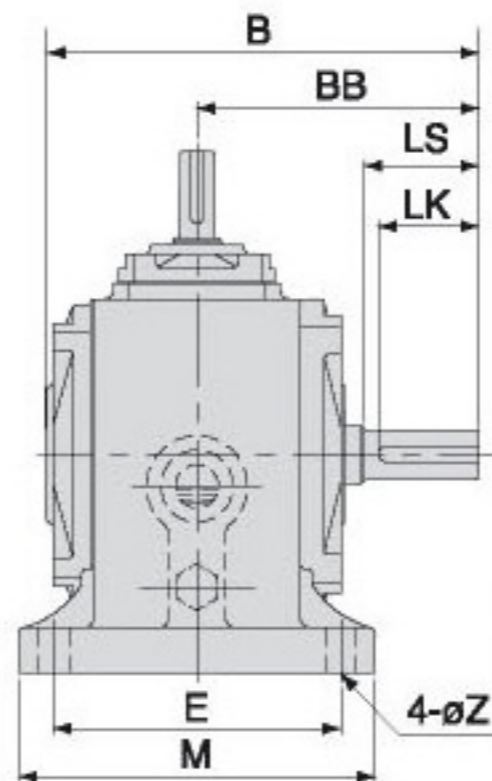
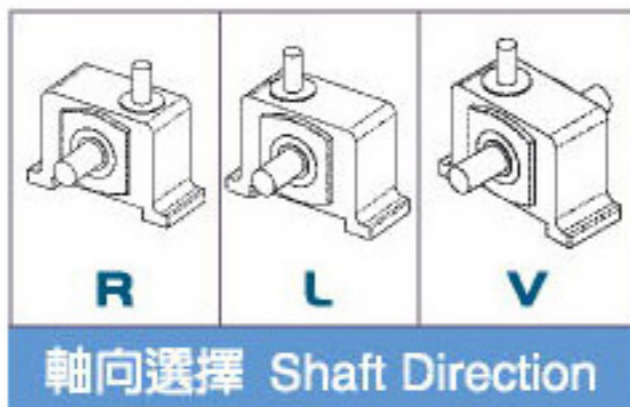

尺寸表 Dimension(m/m)

減速比 RATIO	馬力 HP		H	LL	CC	B	BB	腳座 FOOT STOCK					入力軸 INPUT SHAFT				出力軸 OUTPUT SHAFT				重量 Weight KG		
	MODEL 型號	1/10- 1/30						1/40- 1/60	F1	F2	E	M	N	G	Z	HS	U	d	TxVxHK	LS		S	D
50	1/4		181	76	50	149	98	53	77	100	125	161	15	11	30	12	13.5	4x4x25	40	17	19	5x5x35	7
60	1/2	1/4	210	90	60	164	110	67	98	105	130	205	20	11	40	15	17	5x5x35	50	22	25	7x7x45	9.8
70	1	1/2	235	95	70	193	130	75	115	120	150	230	20	15	40	18	20	5x5x35	60	28	31	7x7x55	13.4
80	2	1	266	105	80	210	140	90	125	125	160	264	20	15	50	22	25	7x7x45	65	32	35	10x8x60	18.4
100	3	2	325	135	100	260	170	100	150	155	195	310	25	15	50	25	28	7x7x45	75	38	41	10x8x70	40.4
120	5	3	391	160	120	288	190	120	180	180	230	360	28	18	65	30	33	7x7x60	85	45	48	12x8x80	57.8
135	7 1/2	5	428	170	135	322	214	130	200	200	250	390	30	18	75	35	38	10x8x70	95	55	59	15x10x90	80