

# 微型齒輪減速機系列 GEARMOTOR SERIES

## 電磁剎車馬達 Electromagnetic Brake Motor



### 電磁煞車馬達 Electro magnetic Brake Motor

特徵：適用於單相或三相馬達緊急剎車作業。在電源斷電的時候，馬達會瞬間停止並具有負載保持力。

Features: Applicable to single-phase or 3-phase emergency brake.

When power is interrupted, motor will instantly stop and maintain the loading.

### 馬達一般規格 Motor general specification

絕緣阻抗：在馬達的線圈與外殼間以DC500V高阻計測定其數值在100MΩ以上。

絕緣耐壓：在馬達的線圈與外殼間施加50Hz或60Hz、1.5KV、1分鐘無發生異常現象。

溫度上升：於馬達額定運轉後以電阻法測定，溫度上升值在80℃以下。

絕緣等級：B種(130℃)。保護等級：導線型IP20。

使用溫度：-10℃~+50℃(電容運轉馬達-10℃~+40℃)(不結凍狀態)

使用溼度：85%以下(不結露狀態)

Insulation impedance: Measure with DC500V high impedance gauge between the coil and casing of motor, the reading is 100M or higher.

Insulation resistance to pressure: Apply 50Hz or 60Hz, 1.5KV between the coil and casing of motor for one minute without in irregularity resulted.

Temperature rise: Specify with resistance method after motor has reached rated operation, the temperature is less than 80℃.

Insulation : B type class (130℃)

Protection : motor with conductive wire is IP20

Operating temperature: -100C~+500C (capacitor operating motor -100C~+400C) (No freezing)

Operating humidity: 85% or less (no condensation)

### 電磁馬達接線圖 Electric magnetic motor wiring diagram

#### ● 單相馬達 Single-phase motor

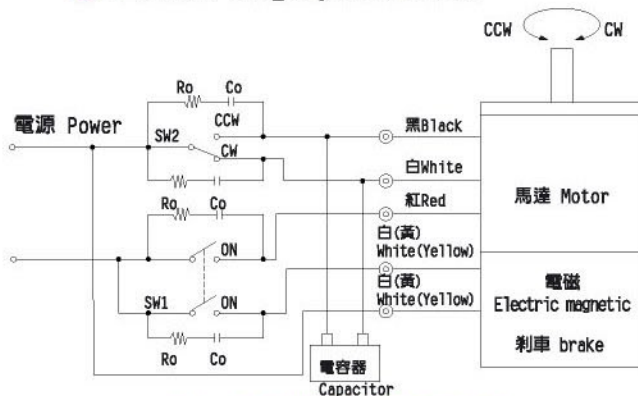

RoCo 為吸收突波用的CR迴路  
CR circuit to absorb surge current

#### ● 三相馬達 Three-phase motor

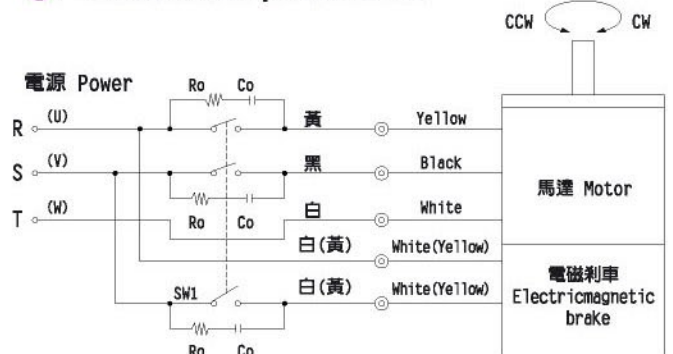

RoCo 為吸收突波用的CR迴路

CR circuit to absorb surge current

註：06、07型電磁剎車馬達開發中

Note: Electromagnetic brake motor for model 06 and 07 will be available soon.

## 電磁剎車馬達機型一覽表 List of electromagnetic brake motor models

型號 Model		輸出功率 Output power (W)	電壓 Voltage (V)	極數 Poles (P)	頻率 Frequency (Hz)	起動轉矩 Starting Torque (Kgcm)	額定轉矩 Rated torque (Kgcm)	額定電流 (A)	額定轉速 Rated rpm (r/min)	電容器容量 Capacitor capacity ( $\mu$ )
圓軸 Round shaft	齒軸 Gear									
CM06IA06SA	CM06IG06SA	6	1Ø110	4	50	0.44	0.50	0.25	1300	2.5(250V)
					60	0.45	0.38	0.22	1630	
CM06IA06SB	CM06IG06SB		1Ø220	4	50	0.40	0.45	0.14	1300	0.7(450V)
					60	0.53	0.38	0.12	1360	
CM07IA15SA	CM07IG15SA	15	1Ø110	4	50	0.81	1.22	0.38	1300	5(250V)
					60	1.00	0.98	0.34	1600	
CM07IA15SB	CM07IG15SB		1Ø220	4	50	0.88	1.22	0.20	1200	1.2(450V)
					60	0.86	0.97	0.18	1600	
CM08IA25SA	CM08IG25SA	25	1Ø110	4	50	1.30	1.87	0.43	1300	6(250V)
					60	1.20	1.48	0.45	1600	
CM08IA25SB	CM08IG25SB		1Ø220	4	50	1.45	1.82	0.21	1330	1.5(450V)
					60	1.57	1.50	0.20	1640	
CM08IA25TB	CM08IG25TB	25	3Ø220	4	50	5.94	2.06	0.23	1300	--
					60	4.86	1.63	0.21	1600	
CM08IA25TC	CM08IG25TC		3Ø380	4	50	5.90	1.75	0.15	1300	--
					60	4.86	1.46	0.13	1550	
CM09IA40SA	CM09IG40SA	40	1Ø110	4	50	2.26	3.00	0.83	1350	10(250V)
					60	2.17	2.50	0.70	1650	
CM09IA40SB	CM09IG40SB		1Ø220	4	50	2.17	3.40	0.46	1350	2.5(450V)
					60	2.15	2.84	0.37	1650	
CM09IA40TB	CM09IG40TB	40	3Ø220	4	50	10.4	3.17	0.31	1400	--
					60	7.90	2.80	0.26	1650	
CM09IA40TC	CM09IG40TC		3Ø380	4	50	8.14	3.00	0.15	1350	--
					60	6.17	3.00	0.13	1600	
CM09IA60SAF	CM09IG60SAF	60	1Ø110	4	50	3.90	4.86	1.58	1350	16(250V)
					60	3.80	4.00	1.10	1650	
CM09IA60SBF	CM09IG60SBF		1Ø220	4	50	3.35	4.37	0.58	1350	4(450V)
					60	3.10	4.30	0.58	1600	
CM09IA60TBF	CM09IG60TBF	60	3Ø220	4	50	17.4	4.90	0.60	1350	--
					60	13.9	4.00	0.45	1600	
CM09IA60TCF	CM09IG60TCF		3Ø380	4	50	13.0	4.85	0.25	1325	--
					60	9.74	3.88	0.21	1600	
CM09IA90SAF	CM09IG90SAF	90	1Ø110	4	50	6.00	6.35	1.58	1375	20(250V)
					60	5.20	5.28	1.43	1650	
CM09IA90SBF	CM09IG90SBF		1Ø220	4	50	6.00	6.20	0.74	1350	6(450V)
					60	6.00	5.43	0.85	1650	
CM09IA90TBF	CM09IG90TBF	90	3Ø220	4	50	17.4	6.50	0.70	1350	--
					60	17.2	5.30	0.57	1650	
CM09IA90TCF	CM09IG90TCF		3Ø380	4	50	17.4	6.20	0.35	1350	--
					60	15.0	5.30	0.30	1600	

● 如馬達特性變更，恕不另行通知，以馬達銘牌為準

In case of change of motor characteristics, no further notice shall be given. The information shown on the nameplate of motor is taken as standard.



# 微型齒輪減速機系列 GEARMOTOR SERIES

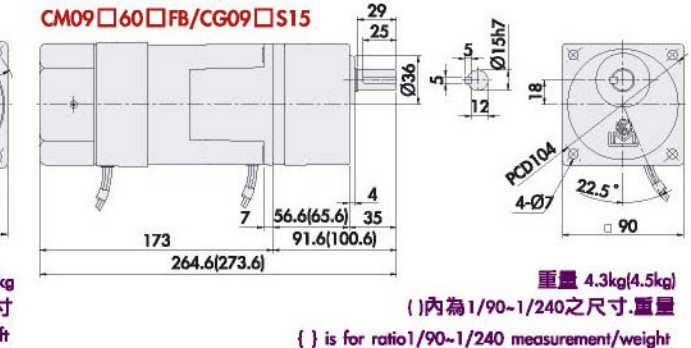
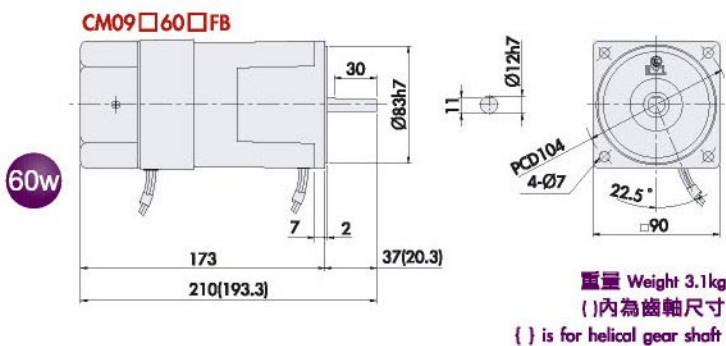
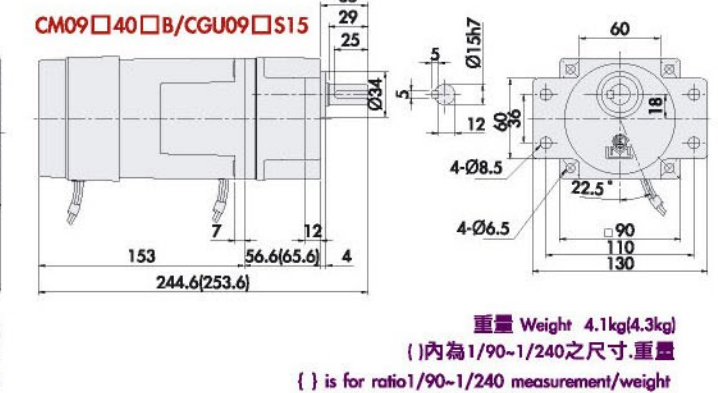
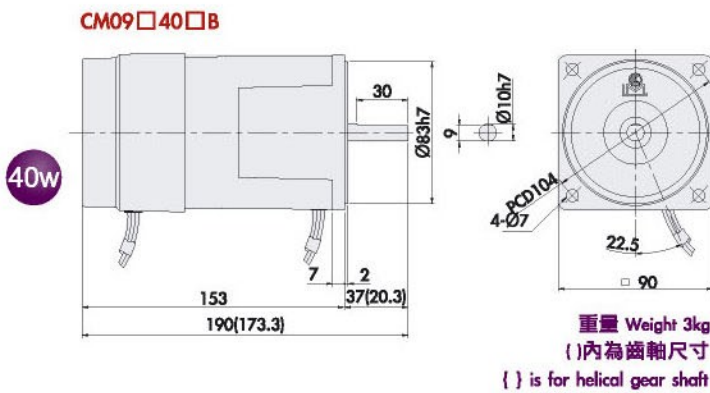
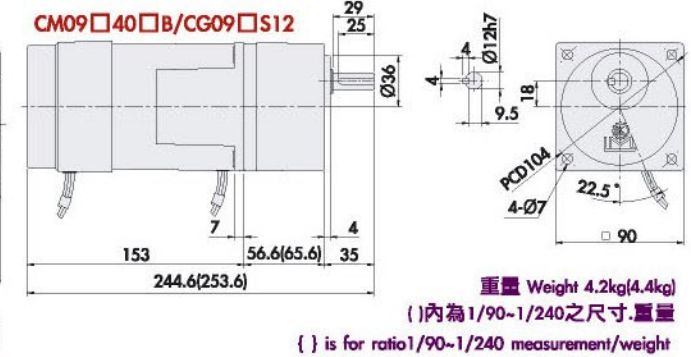
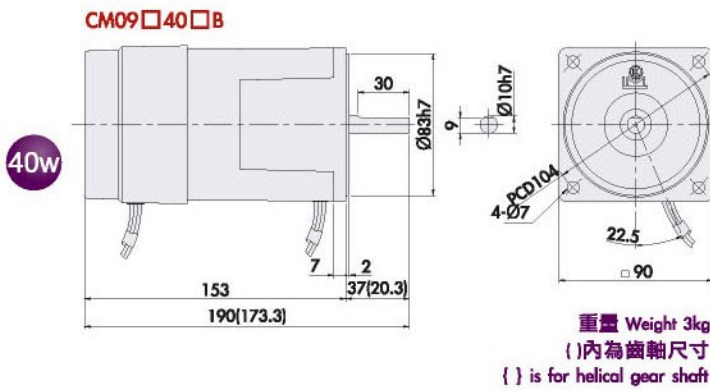
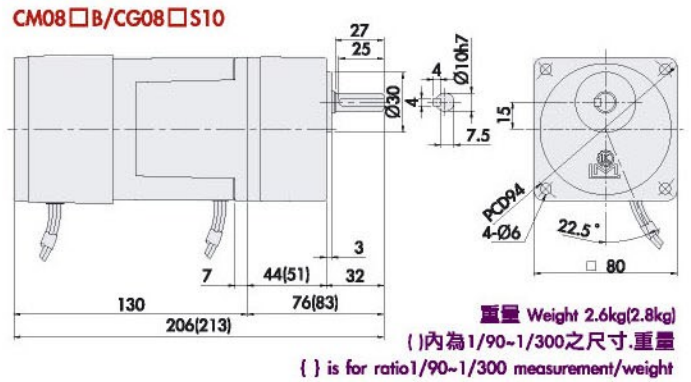
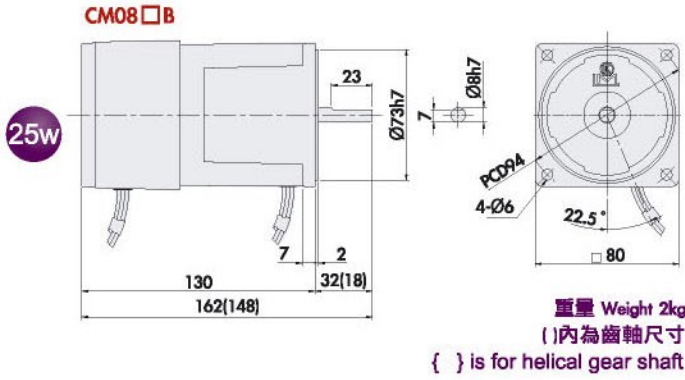

60w

CM09□60□FB

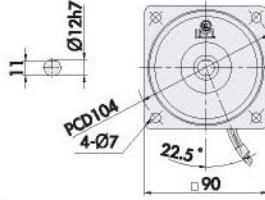
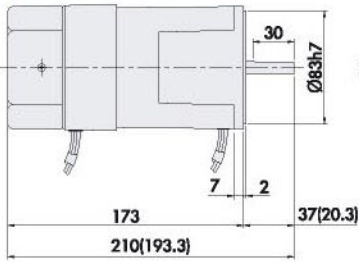

重量 Weight 3.1kg  
( )內為齒軸尺寸  
{ } is for helical gear shaft

CM09□60□FB/CGU09□S15

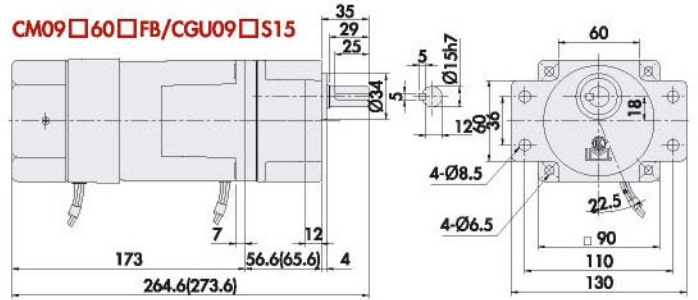

重量 Weight 4.2kg(4.4kg)  
( )內為1/90~1/240之尺寸.重量  
{ } is for ratio 1/90~1/240 measurement/weight

90w

CM09□90□FB

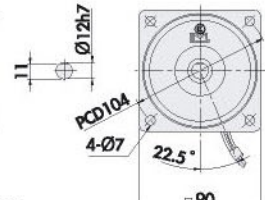
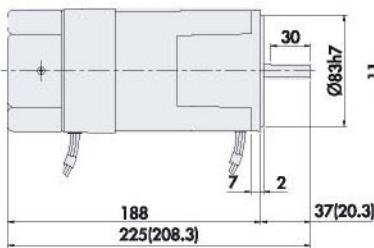

重量 Weight 3.8kg  
( )內為齒軸尺寸  
{ } is for helical gear shaft

CM09□90□FB/CG09□S15

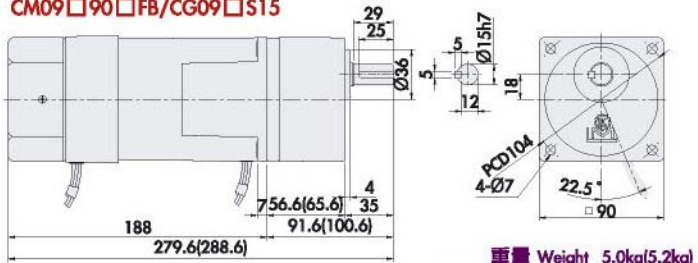

重量 Weight 5.0kg(5.2kg)  
( )內為1/90~1/240之尺寸.重量  
{ } is for ratio 1/90~1/240 measurement/weight

90w

CM09□90□FB

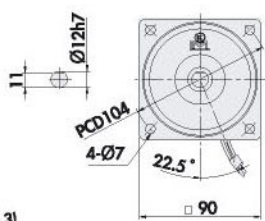
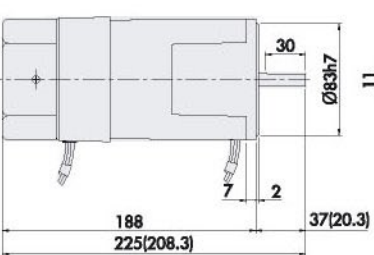

重量 Weight 3.8kg  
( )內為齒軸尺寸  
{ } is for helical gear shaft

CM09□90□FB/CGU09□S15

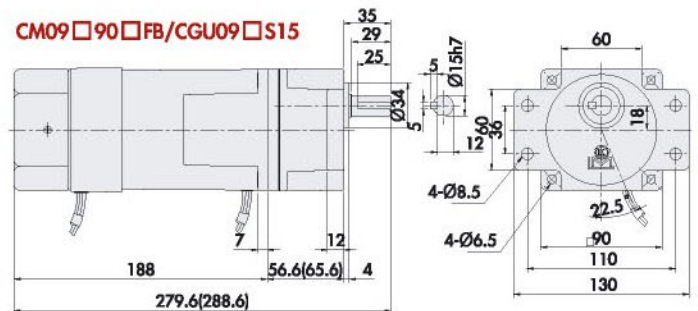

重量 Weight 4.9kg(5.1kg)  
( )內為1/90~1/240之尺寸.重量  
{ } is for ratio 1/90~1/240 measurement/weight

中國綫 1/10 減速機 medium gear box 1/10

CG09B10X

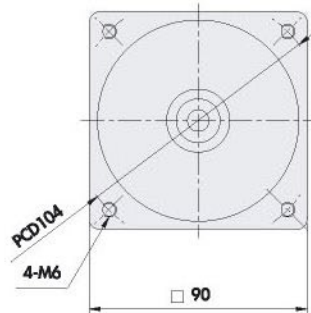
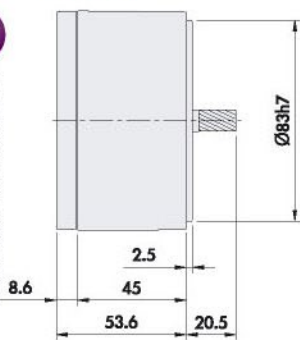

重量 Weight 0.7kg  
( )內為齒軸尺寸  
{ } is for helical gear shaft

CG08B10X

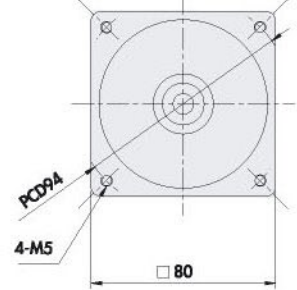
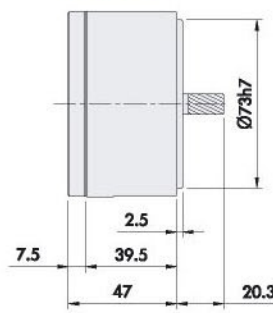

重量 Weight 0.4k