

立式減速機 VERTICAL TYPE REDUCER

MODEL: SV

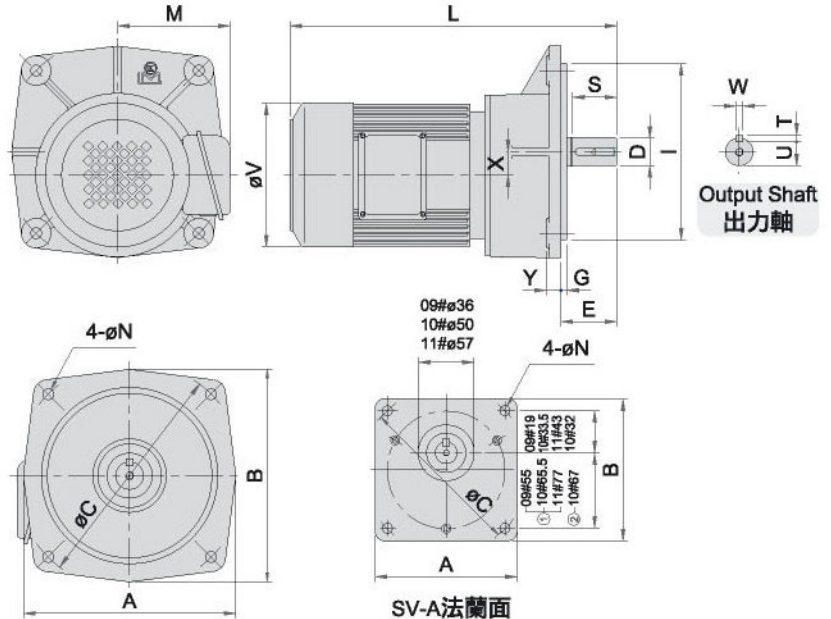

SV(B法蘭面)
型號Model: 10, 11, 12, 13, 14

1. 型號Model: 09, 10, 11
有凸托架(WITH CONVEX TRAILER)
2. 型號Model: 10
無凸托架(WITHOUT CONVEX TRAILER)

尺寸表 Dimension

單位: m/m

馬達容量 Motor Capacity	型號 Model No.	減速比 Gear Ratio	尺寸 (mm)													出力軸 Output Shaft					重量 Weight (kg) 約
			A	B	C	M	N	I	E	G	Y	X	L	V	D	S	W	T	U		
60W	SV-A09	1/3~1/230	92	92	104	95	7	39.5	4.5	10.5	18	268	98	12	33	4	4	9.5	4		
90W		1/3~1/100(1/110~1/230)	92	92	104	95	7	39.5	4.5	10.5	18	283	98	15	33	5	5	12			
0.1 KW 1/8HPx4P	SV-A10	1/3~1/50(1/60~1/100)	122	122	140	100	9	33	10	17	285	119	18	30	5	5	15	5			
	SV-B10		158	158	170	100	9	120	36	3	10	17	285	119	18	30	5	5	15		
	SV-A11	1/60~1/200	145	145	170	100	11	46	4	12	18	300	119	22	40	7	7	18	7		
	SV-11		174	174	185	100	11	140	50	4	12	18	300	119	22	40	7	7	18	7	
0.2 KW 1/4HPx4P	SV-A10	1/3~1/30(1/40~1/60)	122	122	140	110	9	33	10	17	290	133	18	30	5	5	15	5			
	SV-B10		158	158	170	110	9	120	36	3	10	17	290	133	18	30	5	5	15	8	
	SV-A11	1/40~1/90(1/100~1/120)	145	145	170	110	11	46	4	12	18	315	133	22	40	7	7	18	10		
	SV-11		174	174	185	110	11	140	50	4	12	18	315	133	22	40	7	7	18	10	
0.4 KW 1/2HPx4P	12	1/100~1/200	217	217	235	110	11	180	58	6	15	23	330	133	28	45	7	7	24	11	
	SV-A11	1/3~1/30(1/40~1/60)	145	145	170	115	11	46	4	12	18	320	147	22	40	7	7	18	12		
	SV-11		174	174	185	115	11	140	50	4	12	18	320	147	22	40	7	7	18	12	
	12	1/40~1/90(1/100~1/120)	217	217	235	115	11	180	58	6	15	23	335	147	28	45	7	7	24	13	
0.75 KW 1HPx4P	13	1/100~1/200	250	250	280	115	13	220	66	5	17	26	365	147	32	55	10	8	27	16	
	12	1/3~1/30(1/40~1/60)	217	217	235	135	11	180	58	6	15	23	350	161	28	45	7	7	24	16	
	13	1/30~1/90(1/100~1/120)	250	250	280	135	13	220	66	5	17	26	380	161	32	55	10	8	27	19	
	14	1/100~1/200	260	276	310	135	18	230	77	5	20	28	425	161	40	65	10	8	35	44	
1.5 KW 2HPx4P	12	(1/3~1/40)	217	217	235	150	11	180	58	6	15	23	390	181	28	45	7	7	24	25	
	13	1/3~1/25(1/30~1/50)	250	250	280	150	13	220	66	5	17	26	415	181	32	55	10	8	27	28	
	14	1/60~1/100(1/125~1/170)	260	276	310	150	18	230	77	5	20	28	460	181	40	65	10	8	35	46	
2.2 KW 3HPx4P	13	1/3~1/25	250	250	280	150	13	220	66	5	17	26	455	181	32	55	10	8	27	28	
	14	1/30~1/50(1/60~1/100)	260	276	310	150	18	230	77	5	20	28	500	181	40	65	10	8	35	46	

- 註: 1.表中()內數字係表示輕荷重使用。
2.表中重量以配合三相馬達為主, 其它單相、剎車、直流、特殊等馬達重量另訂。
3.表中L內數字以三相為主, 剎車及其它特殊馬達另訂。
4.馬達單頻, 單雙電壓依設計所需另訂。
5.以上數值若有變更, 恕不另行通知。

NOTES:

- 1.Values shown in paranthesis () are used for light loading.
2.Weights shown in the above chart are based on 3-phase, motors, weights for single phase, brake, DC, or special motor shall be referred to specific values.
3.Values shown in "L" column are based on 3-hase, brake for other special motor refer to specific values.
4.When the need arises to determine the special voltage frequency for single phase, please contact the LI-Ming application engineering team.
5.Above specifications are subject to change without prior notice.