

中空軸蝸輪減速機

HOLLOW OUTPUT SHAFT WORM GEAR REDUCER

MODEL: SNEOM

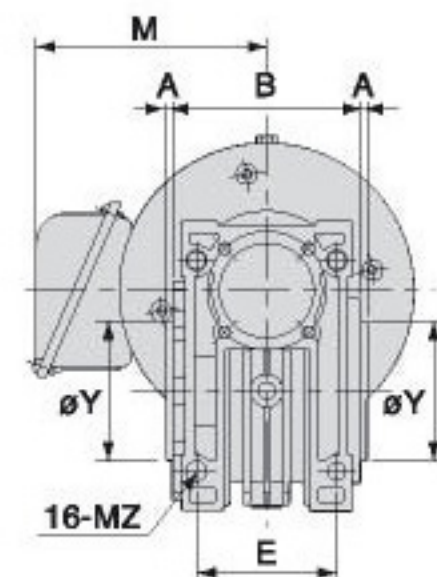
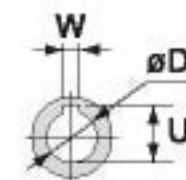
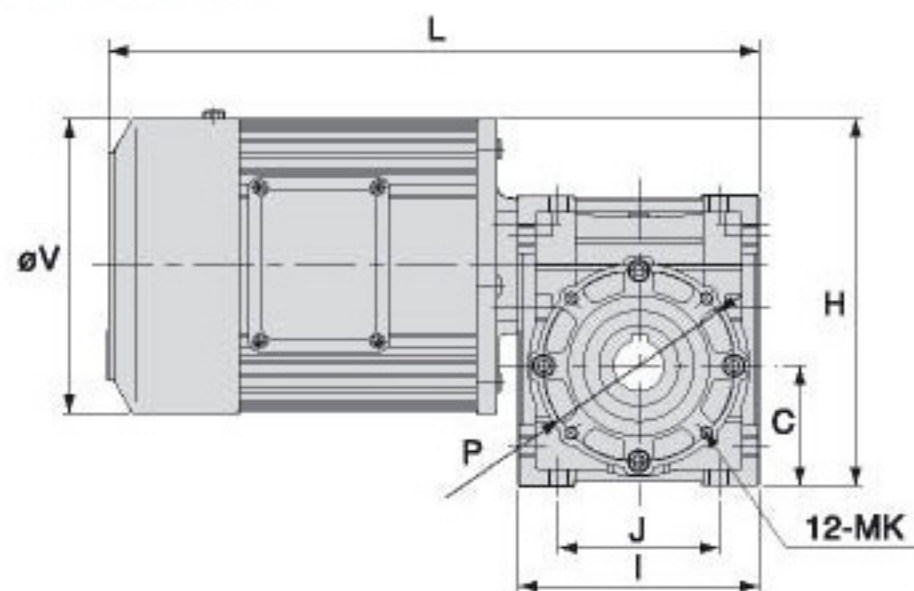

尺寸表 Dimension(m/m)

馬達容量 Motor Capacity	型號 Model No.	減速比 Gear Ratio	A	E	B	J	I	C	H	Y	L	M	V	K	P	Z	出力軸 Output Shaft			重量 Weight (kg)約
																	W	D	U	
0.1KW 1/8HPx4P	40	1/5~1/60	2	60	80	70	102	50	148	60	295	100	119	M6	77	M8	6	20	22.8	6.5
0.2KW 1/4HPx4P		1/5~1/50 (1/60)	2	60	80	70	102	50	155	60	300	110	133	M6	77	M8	6	20	22.8	8
0.4KW 1/2HPx4P		1/5~1/10 (1/20~1/30)	2	60	80	70	102	50	164	60	310	115	147	M6	77	M8	6	20	22.8	9
0.2KW 1/4HPx4P	50	1/5~1/40 (1/50~1/60)	3	70	94	80	120	60	175	70	320	110	133	M6	95	M10	8	25	28.3	9.5
0.4KW 1/2HPx4P		1/5~1/30 (1/40~1/60)	3	70	94	80	120	60	184	70	325	115	147	M6	95	M10	8	25	28.3	10.5
0.75KW 1 HPx4P		1/5 (1/10~1/20)	3	70	94	80	120	60	190	70	345	135	161	M6	95	M10	8	25	28.3	13.5
0.4KW 1/2HPx4P	60	1/5~1/60	3	85	102	100	146	75	209	80	355	115	147	M8	120	M10	8	25	28.3	12.5
0.75KW 1 HPx4P		(1/5~1/40)	3	85	102	100	146	75	216	80	375	135	161	M8	120	M10	8	25	28.3	15.5
0.4KW 1/2HPx4P	70	1/5~1/60	3	90	118	120	170	85	229	90	380	115	147	M10	140	M10	8	30	33.3	17
0.75KW 1 HPx4P		1/5~1/40 (1/50~1/60)	3	90	118	120	170	85	236	90	400	135	161	M10	140	M10	8	30	33.3	20
1.5KW 2 HPx4P		1/5~1/10 (1/15~1/30)	3	90	118	120	170	85	246	90	435	150	181	M10	140	M10	8	30	33.3	25

- 註：1.表中()內數字係表示輕荷重使用。
 2.表中重量以配合三相馬達為主，其它單相、剎車、直流、特殊等馬達重量另訂。
 3.表中L內數字以三相為主，剎車及其它特殊馬達另訂。
 4.馬達單頻，單雙電壓依設計所需另訂。
 5.以上數值若有變更，恕不另行通知。

- NOTES:
 1.Values shown in paranthesis () are used for light loading.
 2.Weights shown in the above chart are based on 3-phase, motors, weights for single phase, brake, DC, or special motor shall be referred to specific values.
 3.Values shown in "L" column are based on 3-hase, brake for other special motor refer to specific values.
 4.When the need arises to determine the special voltage frequency for single phase, please contact the Li-Ming application engineering team.
 5.Above specifications are subject to change without prior notice.