

■ 臥式高速比多段減速機

HORIZONTAL, HIGH GEAR RATION & MULTI-STAGE REDUCER

■ MODEL: SHLS

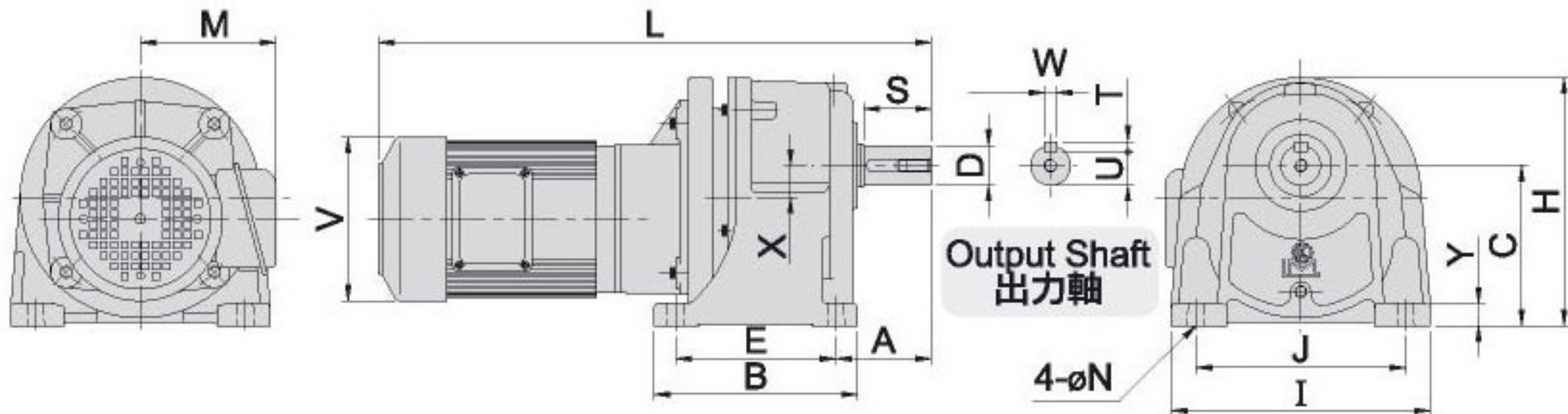

尺寸表 Dimension

單位：m/m

馬達容量 Motor Capacity	型號 Model No.	減速比 Gear Ratio	A	E	B	J	I	C	H	Y	N	X	L	M	V	出力軸 Output Shaft					重量 Weight (kg)約
																D	S	W	T	U	
60 W	11	1/2000 以上	58	65	90	130	155	95	145	13	9	18	373	95	98	22	40	7	7	18	10
90 W	11		58	65	90	130	155	95	145	13	9	18	388	95	98	22	40	7	7	18	10
0.1 KW 1/8HPx4P	12		66	90	120	140	180	115	175	15	11	23	415	100	119	28	45	7	7	24	12
0.2 KW 1/4HPx4P	13		78	130	165	170	210	130	202	18	13	26	449	110	133	32	55	10	8	27	18
0.4 KW 1/2HPx4P	14		95	150	195	210	255	150	240	20	15	28	515	115	147	40	65	10	8	35	35
0.75 KW 1HPx4P	15	1/700以上	115.5	170	230	265	330	185	293	25	19	38	579	135	161	50	80	14	9	44.5	58

註：多速比減速機以定轉速設計，請參考齒箱最大容許扭力。 Note: This multistage gear reducer is designed to rotate at fixed speed. Please refer to the maximum allowable torque of the gear box.