

■ 馬達插入式臥式減速機 HORIZONTAL TYPE REDUCER MOTOR PLUG-IN

■ MODEL : HB

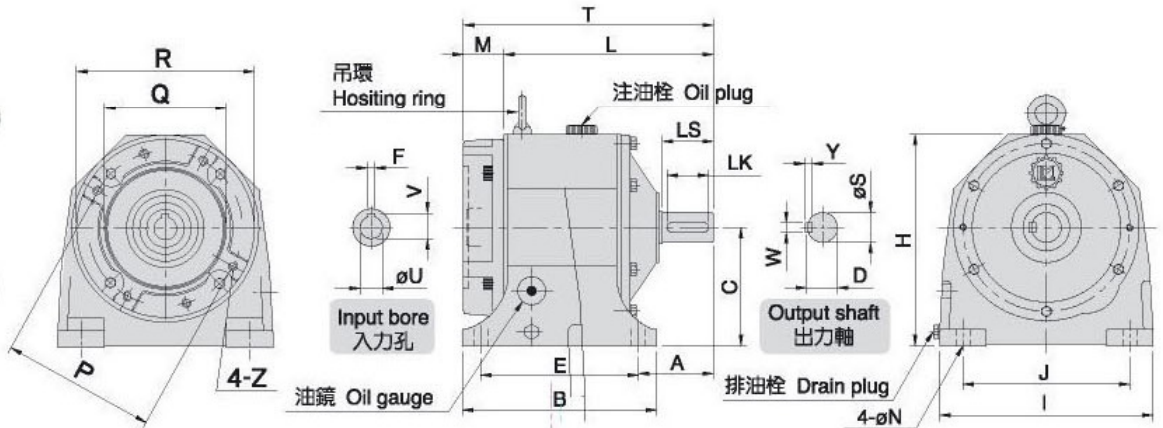

■ 二段式 2-STAGE

■ 減速比 RATIO 1/3~1/40

尺寸表 Dimension

單位 : m/m

型號 MODEL	馬力 HP (4P)	減速比 RATIO	T	H	L	C	A	腳座 FOOT STOCK					馬達盤 IEC MOTOR FLANGE					入力孔 INPUT BORE			出力軸 OUTPUT SHAFT				重量 Weight (KG)
								E	J	B	I	N	M	P	Q	R	Z	U	F	V	D	LS	S	WxYxLK	
★HB-201	1/4	3~30	194	170	165	90	53	125	140	155	180	10	29	130	110	160	M8	11	4	12.7	21	38	19	5x5x30	12
★HB-202	1/2	3~10	199	170	172	90	60	125	140	155	180	10	29	130	110	160	M8	14	5	16.3	27	45	24	7x7x35	12
HB-203	1/4	31~50	210	190	180	110	62	135	145	170	190	13	29	130	110	160	M8	11	4	12.7	27	45	24	7x7x35	15
	1/2	11~30																14	5	16.3					
HB-205	1/2	31~50	251	227	222	127	77	170	180	210	230	15	26	130	110	200	M8	14	5	16.3	31	50	28	7x7x40	27
	1	3~30	255	222	33	165	130	M10	19	6	21.8														
HB-206	2	3~10	270	227	226	127	80	170	180	210	230	15	44	165	130	200	M10	24	8	27.3	35	55	32	10x8x45	27
HB-207	1	31~40	298	253	254	145	80	205	195	240	260	15	44	165	130	200	M10	19	6	21.8	35	55	32	10x8x45	33
	2	11~30	298	253	44	165	130	200	M10	24	8	27.3													
HB-208	3	3~10	315	265	262	145	87	205	195	240	260	15	57	215	180	250	M12	28	8	31.3	41	60	38	10x8x50	38
HB-209	2	31~40	323	289	279	164	88	215	215	265	295	19	49	165	130	250	M10	24	8	27.3	41	60	38	10x8x50	51
	3	11~30	337	279	57	215	180	250	M12	28	8	31.3													
HB-210	5	3~10	341	289	283	164	92	215	215	265	295	19	57	215	180	250	M12	28	8	31.3	45	65	42	12x8x55	51
HB-211	3	31~40	382	332	325	192	109	250	270	310	340	19	57	215	180	250	M12	28	8	31.3	51	75	48	12x8x65	72
	5	11~30																							
HB-212	7 1/2	3~10	390	332	325	192	109	250	270	310	340	19	65	265	230	300	M12	38	10	41.3	51	75	48	12x8x65	77
	10	3~10																							
HB-213	7 1/2	11~30	450	385	385	210	126	310	310	370	405	22	65	265	230	300	M12	38	10	41.3	60	80	56	15x10x70	114
	15	4~10	470	85	300	250	350	M16	42	12	45.3														
HB-214	10	11~30	455	385	390	210	131	310	310	370	405	22	65	265	230	300	M12	38	10	41.3	66	85	62	15x10x75	114
HB-215	15	11~30	553	445	468	245	151	360	360	430	455	25	85	300	250	350	M16	42	12	45.3	76.5	100	72	20x12x90	180
	20	4~10																							
HB-216	20	11~30	554	445	469	245	151	360	360	430	455	25	85	300	250	350	M16	42	12	45.3	80.5	100	76	20x12x90	182
	25	5~10	556	87	350	300	400	48	14	51.8															
HB-217	25	11~30	595	505	508	280	172	380	420	460	535	25	87	350	300	400	M16	48	14	51.8	84.5	110	80	20x12x100	255
	30	4~30																							
HB-218	40	11~30	695	575	608	310	196	480	480	570	605	28	87	350	300	400	M16	55	16	59.3	106.5	130	100	24x16x120	374
	50	5~10																							
HB-219	50	10~30	772	680	685	380	214	540	500	635	670	28		400	350	450	M16	60	18	64.3	124	150	115	32x20x140	597
	60																								

★表使用圓形外殼 ※減速比5,10,15,20,25,30,35,40,50,60,70,80,90,100,120,150,200屬於標準品，其餘皆屬於特殊品。

■ 馬達插入式臥式減速機 HORIZONTAL TYPE REDUCER MOTOR PLUG-IN

■ MODEL : HB

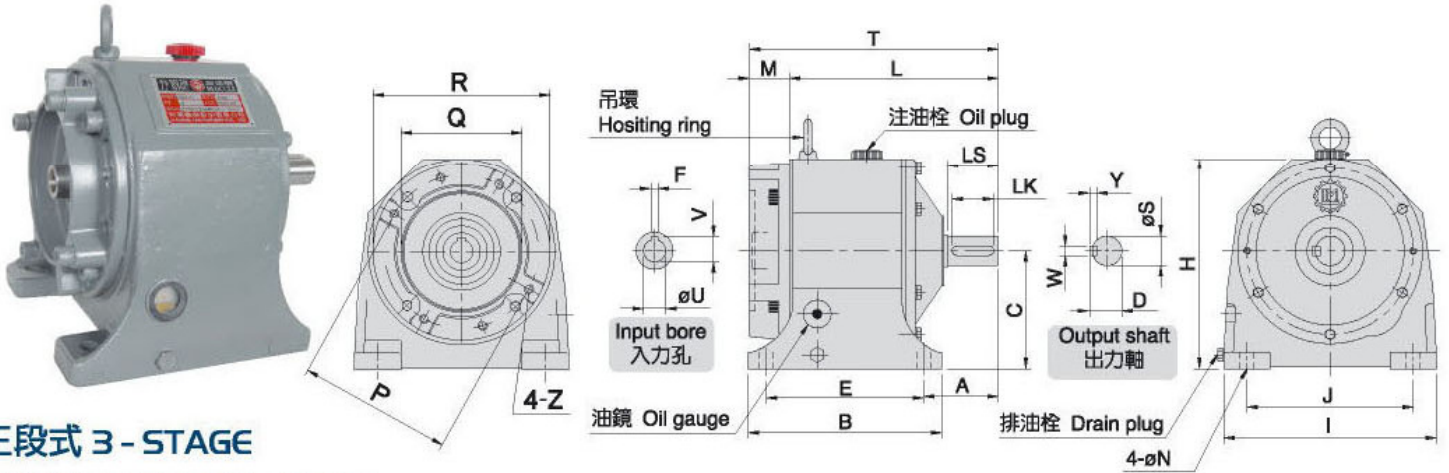

■ 三段式 3-STAGE

■ 減速比 RATIO 1/31~1/200

尺寸表 Dimension

單位 : m/m

型號 MODEL	馬力 HP (4P)	減速比 RATIO	T	H	L	C	A	腳座 FOOT STOCK					馬達盤 IEC MOTOR FLANGE					入力孔 INPUT BORE			出力軸 OUTPUT SHAFT				重量 Weight (KG)
								E	J	B	I	N	M	P	Q	R	Z	U	F	V	D	LS	S	WxYxLK	
HB-304	1/4	51~120	225	190	197	110	66	135	145	175	190	13	29	130	110	160	M8	11	4	12.7	31	50	28	7x7x40	16
HB-306	1/4	121~200	266	227	236	127	80	170	180	210	230	15	30	130	110	200	M8	11	4	12.7	35	55	32	10x8x45	18
	1/2	51~120	266	227	236	127	80	170	180	210	230	15	30	130	110	200	M8	14	5	16.3					
HB-308	1/2	121~200	288		259								29	130	110		M8	14	5	16.3	41	60	38	10x8x50	35
	1	40~120	292	253	259	145	85	205	195	240	260	15	33	165	130	200	M10	19	6	21.8					
HB-310	2	31~40	303										44	165	130		M10	24	8	27.3	45	65	42	12x8x55	53
	1	121~200	339										44	165	130		M10	19	6	21.8					
HB-312	2	51~120	339	289	295	164	92	215	215	265	295	19	49	165	130	250	M10	24	8	27.3	51	75	48	12x8x65	79
	3	31~40	349										57	215	180		M12	28	8	31.3					
HB-314	3	121~200	381		413								49	165	130		M10	24	8	27.3	66	85	62	15x10x75	122
	5	51~120	457	385	413	210	131	310	310	360	405	22	57	215	180	250	M12	28	8	31.3					
HB-315	7 1/2	31~50	467		402								65	265	230	300		38	10	41.3	80.5	100	76	20x12x90	197
	5	121~200	539		485								57	215	180	250		28	8	31.3					
HB-316	7 1/2	35~120	552	445	484	245	151	360	360	430	455	25	68	265	230	300	M12	38	10	41.3	76.5	100	72	20x12x90	195
	10	31~60	552		484								68	265	230	300		38	10	41.3					
HB-317	10	35~120	553	445	485	245	151	360	360	430	455	25	68	265	230	300	M12	38	10	41.3	80.5	100	76	20x12x90	197
	15	31~50	573										88	300	250	350	M16	42	12	45.3					
HB-318	7 1/2	125~200	604		539								65	265	230	300	M12	38	10	41.3	84.5	110	80	20x12x100	259
	15	40~120	608	505	523	280	172	380	420	460	535	25	85	300	250	350	M16	42	12	45.3					
HB-319	20	40~50	608		523								85	300	250	350	M16	42	12	45.3	106.5	130	100	24x16x120	474
	25	40~50	632		545								87	350	300	400	M16	48	14	51.8					
HB-318	10	121~200	693										65	265	230	300	M12	38	10	41.3	106.5	130	100	24x16x120	482
	15	121~200	713										85	300	250	350	M16	42	12	45.3					
HB-318	20	51~120	713	575	628	310	196	480	480	570	605	28	85	300	250	350	M16	42	12	45.3	106.5	130	100	24x16x120	498
	25	60	734										106	350	300	400	M16	48	14	51.8					
HB-319	30	31~50	734										106	350	300	400	M16	48	14	51.8	103	150	115	32x20x140	612
	20	121~200	781										85	300	250	350	M16	42	12	45.3					
HB-319	25	60~90	783	680	696	380	214	540	500	635	670	28	87	350	300	400	M16	48	14	51.8	103	150	115	32x20x140	628
	30	60~90	783										87	350	300	400	M16	48	14	51.8					
HB-319	40	40~60	783										87	350	300	400	M16	55	16	59.3	103	150	115	32x20x140	628

※減速比5,10,15,20,25,30,35,40,50,60,70,80,90,100,120,150,200屬於標準品，其餘皆屬於特殊品。