

FA series

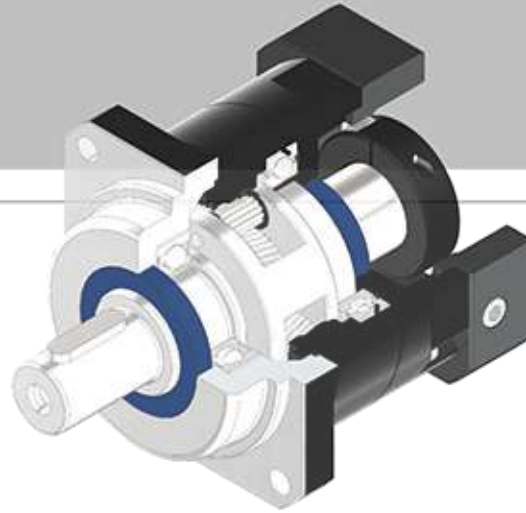

全系列單段背隙 \cong 8 弧分 1-Stage Backlash \cong 8 arcmin
 全系列雙段背隙 \cong 12 弧分 2-Stage Backlash \cong 12 arcmin

Indication of Model Numbers

機種型號表示

FA	80	—	10	□	—	MOTOR
減速機機型 Type	型號 Model		速比 Ratio	出力軸鍵槽 Output Shaft Keyway		馬達型號 Motor Type
FA	50 80 100		單段 1-Stage 3, 4, 5, 7, 10 雙段 2-Stage 15, 20, 25, 30, 35, 40, 50, 70, 100	□標準品，有鍵槽 Standard (Keyway) N:實心軸，無鍵槽 Solid Output Shaft (No Keyway)		

靜音

使用斜齒輪實現順暢安靜地運轉。

Quiet operation

Helical gears contribute to reduce vibration and noise.

高扭矩

比一般正齒輪行星減速機扭矩高。

High Torque

High output torque is in comparison with spur gear planetary gear reducers.

高效率

單段式在 97% 以上，雙段式在 95% 以上。

High Efficiency

Efficiency for 1-stage model exceeds 97%; 2-stage model exceeds 95%.

馬達連接板的模組化設計

獨特的馬達連接板模組化設計，適用於任何廠牌法蘭型式的伺服馬達。

Modular Design of Motor Connection Plate

The special modular design of motor connection plate is suitable for any flange mounting servomotors.

無潤滑脂洩漏、維護方便

使用高粘度、不易分離的潤滑脂，有效防潤滑脂洩漏。在產品壽命期內無需更換潤滑脂，安裝更便捷。

No grease leakage & Maintenance-free

Perfect solution using high viscosity anti-separation grease. No need to replace the grease during product life. Convenient in stallation is the advantage.

Features of FA Series

FA 系列產品特性



螺旋齒輪設計及高精度齒輪加工

減速機構採用螺旋齒輪設計，齒形嚙合率為一般正齒輪的二倍以上，具有運轉平順、低噪音、高輸出扭矩和低背隙的特性。

材料採用高級鎳鉻鉬合金鋼(SNCM220)，切削加工後，經滲碳熱處理至硬度 57~60HRC，再進行齒面研磨，確保齒輪精度 DIN6 級以內。

Helical Gear Design

The speed reduction mechanism employs helical gears, which provides two times meshing rate of teeth when comparing with regular spur gears. In addition, it also features extremely smooth running, low noise, high torque output and low backlash.

High Precision Gear Machining

Manufactured from high quality Ni-Cr-Mo alloy steel (SNCM220), precision machined and carburized to hardness 57-60 HRC. Precision teeth grinding assures gear accuracy reaches DIN6 class.



滿針滾針軸承設計

行星齒輪的傳動介面採用不含保持器之滿針滾針軸承，增加接觸面積以提高結構剛性及使用壽命。

Full Needle Roller Bearings Design

The planetary gear transmission employs full needle roller bearings without retainer to increase the contact surface, which greatly upgrades structural rigidity and service life.



一體式行星臂架

行星臂架與輸出軸採一體式的結構設計，以確保提高扭轉剛性及精確度。

Integrated Planetary Arm Bracket

The planetary arm bracket and the output shaft are one-piece constructed to increase torsional rigidity and accuracy.



一體式齒輪箱本體

齒輪箱和內環齒輪採一體式的設計。提高結構剛性及輸出扭矩。

One-piece Gear Box & Advanced Surface Treatment

The gear box and internal ring gear are one-piece constructed.



筒夾式連結機構

輸入端與馬達的連結採用筒夾式的鎖緊機構，並經動平衡分析，以確保在高輸入轉速下結合介面的同心度和平衡度，及零背隙的動力傳遞。

Collet Locking Mechanism

The input-end and the motor are coupled through a collet locking mechanism. It has passed dynamical balance analysis to assure concentricity and balance on the connection and no backlash for power transmission while running at high speed.

MODEL : FA50

RATIO: 3. 4. 5. 7. 10 (單段 1-Stage)

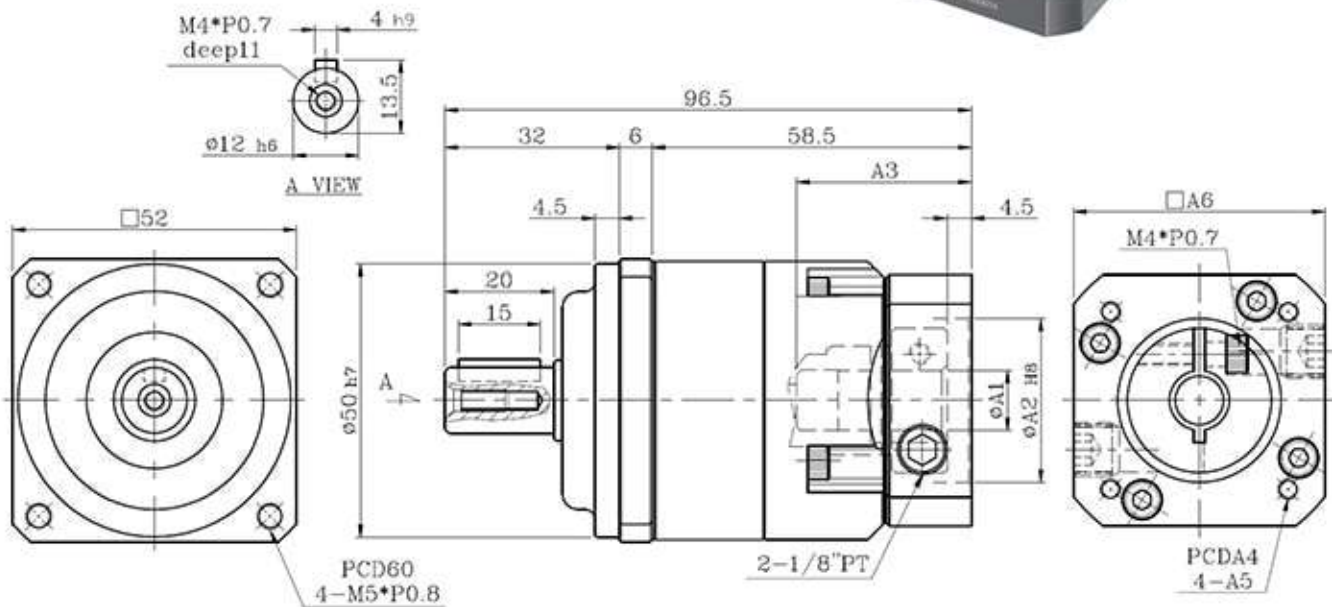

入力法蘭尺寸表 Dimension of Input Flange unit:mm

NO.	ØA1	ØA2	A3	A4	A5	A6
1	11	30	32	45	M3	46
2		30	32	46	M4	46
3		30	32	48.5	M3	55
4		40	32	63	M5	55
5		50	32	70	M5	60

FA50-1 特性表

減速比 Ratio		3	4	5	7	10
額定輸出扭矩 Rated Output Torque	Nm	19	16	16	15	14
最大輸出力矩 Max. Output Torque	Nm	3 倍額定輸出扭矩 3 Times of Rated Output Torque				
額定輸入轉速 Rated Input Speed	rpm	3,000				
最大輸入轉速 Max. Input Speed	rpm	5,000				
扭轉剛性 Torsional Rigidity	Nm/arcmin	3				
容許徑向力 Max. Radial Force	N	350				
容許軸向力 Max. Axial Force	N	180				
使用壽命 Service Life	hr	20,000 (連續運轉壽命 10,000hrs) 20,000 (Continuous operation life 10,000hrs)				
效率 Efficiency	%	≥97%				
使用溫度 Operating Temperature	°C	-25°C~+90°C				
潤滑 Lubrication		全合成潤滑脂 Synthetic Gear Grease				
防護等級 Protection Class		IP 65				
安裝方向 Mounting Position		任意 Any				
噪音值 Noise Level	dB	≤58 dB				
重量 Weight ±2%	Kg					

MODEL : FA50

RATIO: 15. 20. 25. 30. 35. 40. 50. 70. 100

(雙段 2-Stage)

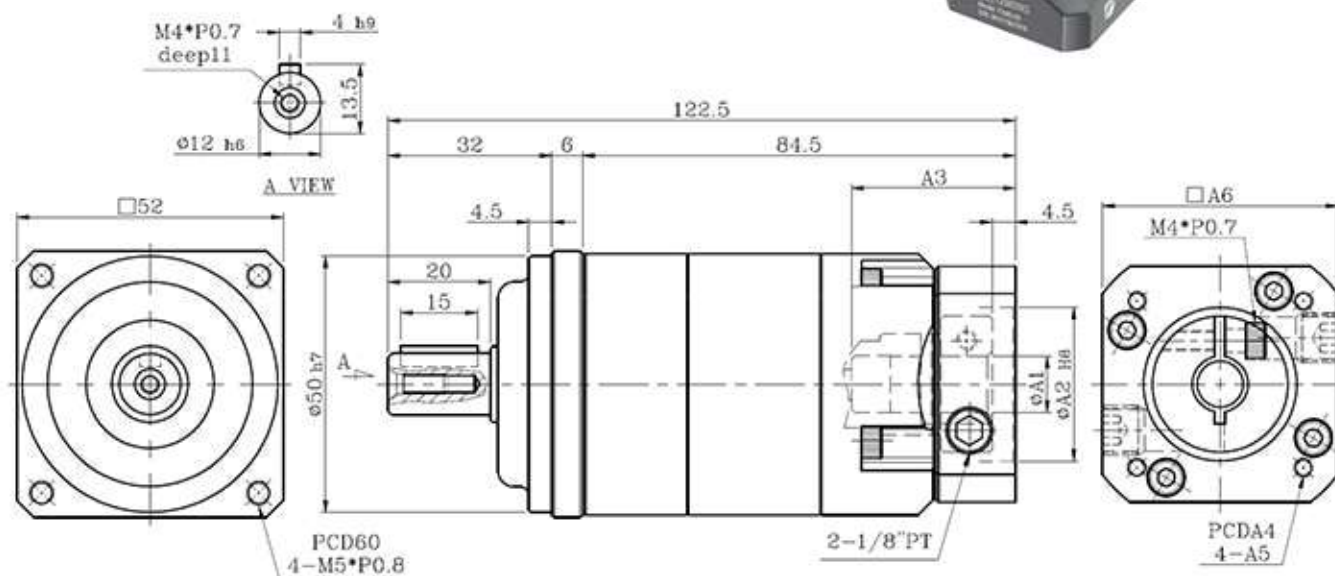

入力法蘭尺寸表 Dimension of Input Flange unit:mm

NO.	ØA1	ØA2	A3	A4	A5	A6
1	11 14	30	32	45	M3	46
2		30	32	46	M4	46
3		30	32	48.5	M3	55
4		40	32	63	M5	55
5		50	32	70	M5	60

FA50-2 特性表

減速比 Ratio		15	20	25	30	35	40	50	70	100	
額定輸出扭矩 Rated Output Torque	Nm	19	16	16	19	15	16	16	15	14	
最大輸出力矩 Max. Output Torque	Nm	3 倍額定輸出扭矩 3 Times of Rated Output Torque									
額定輸入轉速 Rated Input Speed	rpm	3,000									
最大輸入轉速 Max. Input Speed	rpm	5,000									
扭轉剛性 Torsional Rigidity	Nm/arcmin	3									
容許徑向力 Max. Radial Force	N	350									
容許軸向力 Max. Axial Force	N	180									
使用壽命 Service Life	hr	20,000 (連續運轉壽命 10,000hrs) 20,000 (Continuous operation life 10,000hrs)									
效率 Efficiency	%	≥ 95%									
使用溫度 Operating Temperature	°C	-25°C ~ +90°C									
潤滑 Lubrication		全合成潤滑脂 Synthetic Gear Grease									
防護等級 Protection Class		IP 65									
安裝方向 Mounting Position		任意 Any									
噪音值 Noise Level	dB	≤ 60 dB									
重量 Weight ±2%	Kg										

MODEL : FA80

RATIO: 15. 20. 25. 30. 35. 40. 50. 70. 100

(雙段 2-Stage)

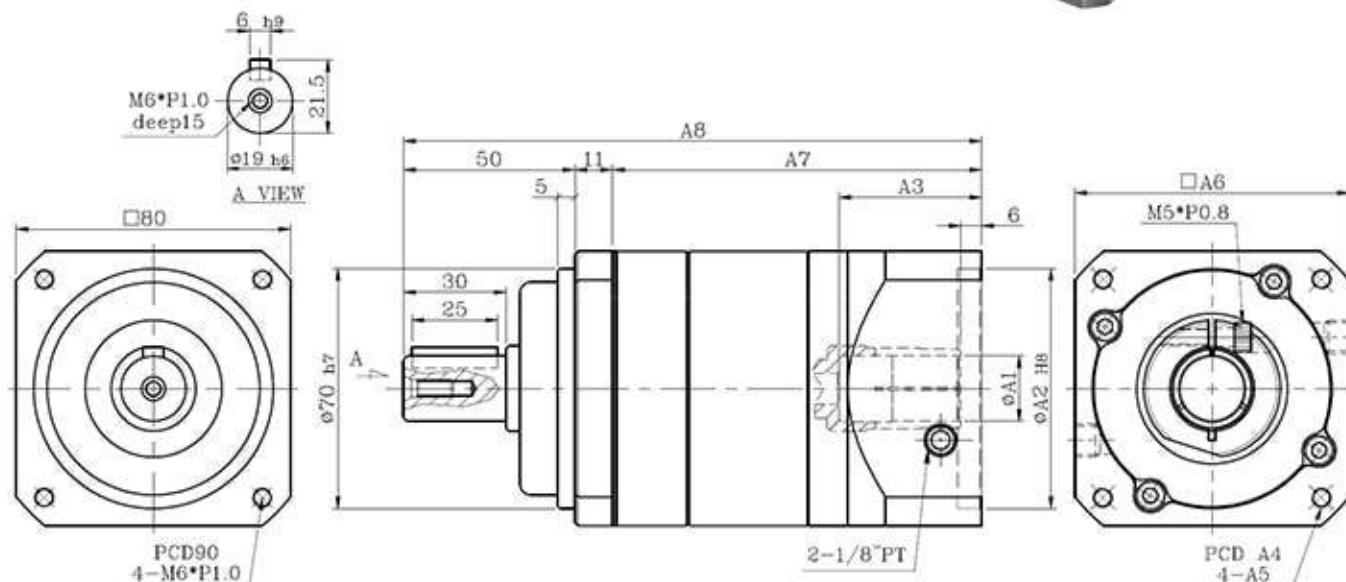

入力法蘭尺寸表 Dimension of Input Flange

unit:mm

NO.	ØA1	ØA2	A3	A4	A5	A6	A7	A8
1	14	50	33.5	70	M5	80	99.5	160.5
2	19	70	41.5	90	M5	80	107.5	168.5
3	25	70	41.5	90	M6	80	107.5	168.5

FA80-2 特性表

減速比 Ratio		15	20	25	30	35	40	50	70	100
額定輸出扭矩 Rated Output Torque	Nm	112	110	108	112	105	110	108	105	100
最大輸出力矩 Max. Output Torque	Nm	3 倍額定輸出扭矩 3 Times of Rated Output Torque								
額定輸入轉速 Rated Input Speed	rpm	3,000								
最大輸入轉速 Max. Input Speed	rpm	5,000								
扭轉剛性 Torsional Rigidity	Nm/arcmin	10								
容許徑向力 Max. Radial Force	N	1,200								
容許軸向力 Max. Axial Force	N	600								
使用壽命 Service Life	hr	20,000 (連續運轉壽命 10,000hrs) 20,000 (Continuous operation life 10,000hrs)								
效率 Efficiency	%	≥95%								
使用溫度 Operating Temperature	°C	-25°C~+90°C								
潤滑 Lubrication		全合成潤滑脂 Synthetic Gear Grease								
防護等級 Protection Class		IP 65								
安裝方向 Mounting Position		任意 Any								
噪音值 Noise Level	dB	≤62 dB								
重量 Weight ±2%	Kg	2.8								

MODEL : FA100

RATIO: 3. 4. 5. 7. 10(單段 1-Stage)

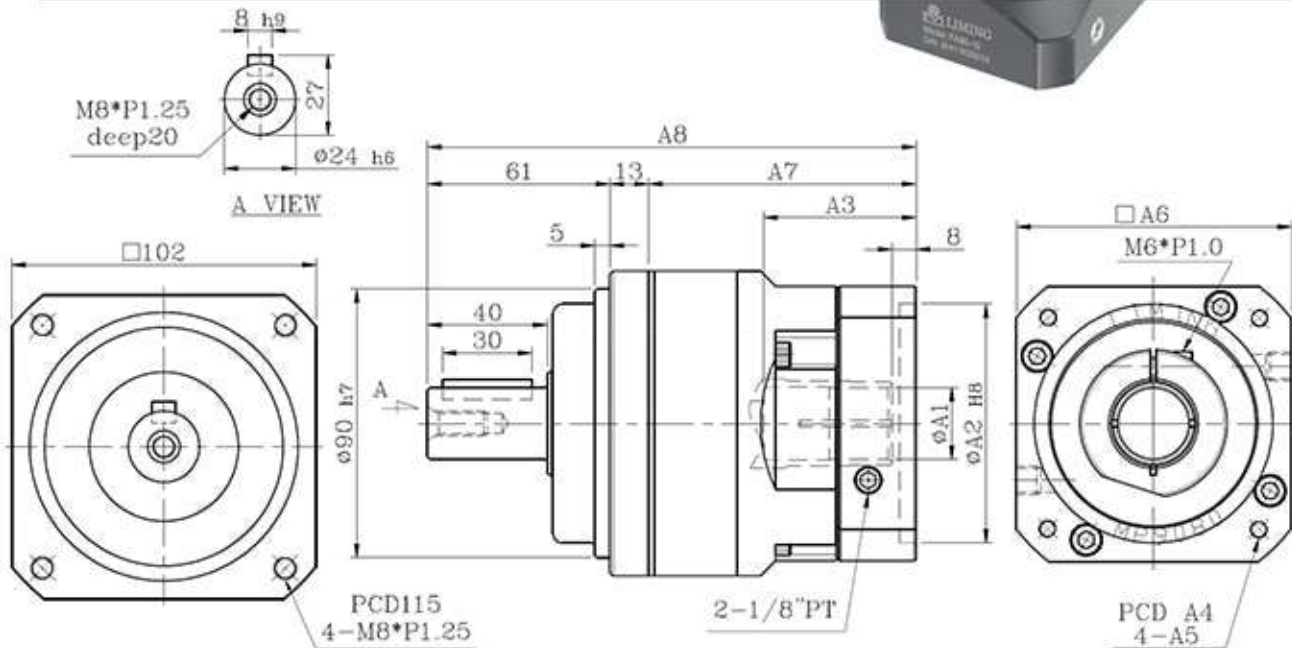

入力法蘭尺寸表 Dimension of Input Flange

unit:mm

NO.	ØA1	ØA2	A3	A4	A5	A6	A7	A8
1	19 ? 24	70	51	90	M6	92	89.5	163.5
2		80	51	100	M6	92	89.5	163.5
3		95	51	115	M6	110	89.5	163.5
4		95	51	115	M8	110	89.5	163.5
5		110	51	145	M8	130	89.5	163.5
6		110	65.5	145	M8	130	104	178

FA100-1 特性表

減速比 Ratio		3	4	5	7	10
額定輸出扭矩 Rated Output Torque	Nm	165	146	160	149	141
最大輸出扭矩 Max. Output Torque	Nm	3 倍額定輸出扭矩 3 Times of Rated Output Torque				
額定輸入轉速 Rated Input Speed	rpm	3,000				
最大輸入轉速 Max. Input Speed	rpm	5,000				
扭轉剛性 Torsional Rigidity	Nm/arcmin	14				
容許徑向力 Max. Radial Force	N	3,200				
容許軸向力 Max. Axial Force	N	1,600				
使用壽命 Service Life	hr	20,000 (連續運轉壽命 10,000hrs) 20,000 (Continuous operation life 10,000hrs)				
效率 Efficiency	%	≥97%				
使用溫度 Operating Temperature	°C	-25°C~+90°C				
潤滑 Lubrication		全合成潤滑脂 Synthetic Gear Grease				
防護等級 Protection Class		IP 65				
安裝方向 Mounting Position		任意 Any				
噪音值 Noise Level	dB	≤65 dB				
重量 Weight ±2%	Kg					

MODEL : FA100

RATIO: 15. 20. 25. 30. 35. 40. 50. 70. 100

(雙段 2-Stage)

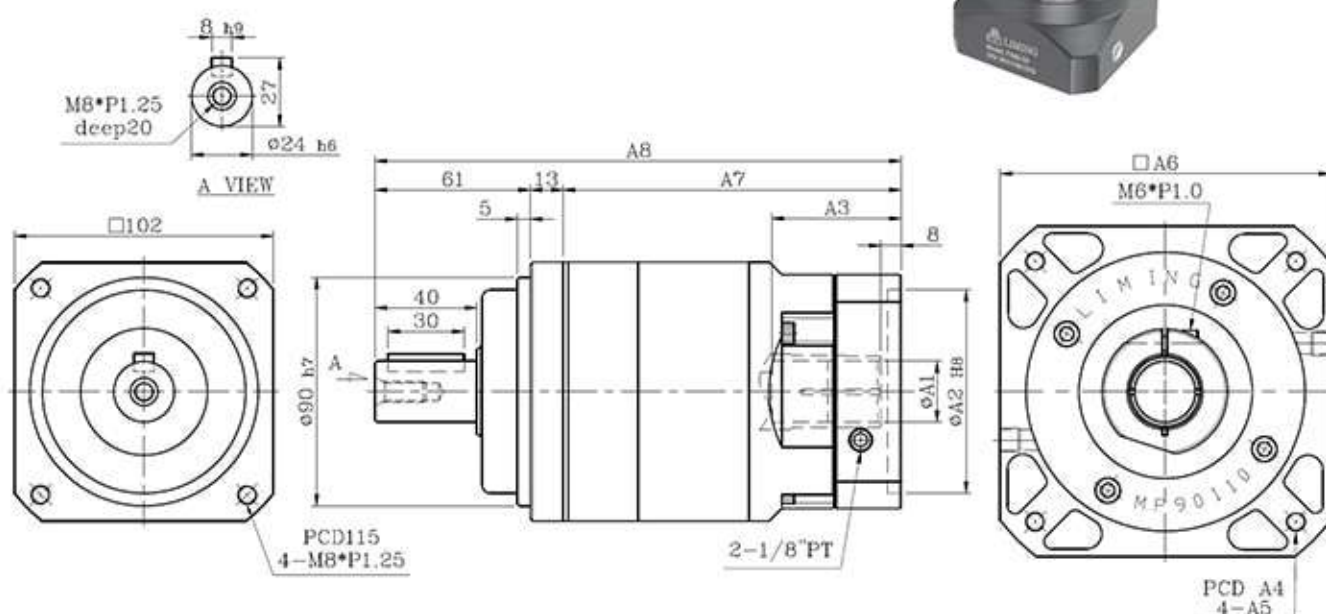

入力法蘭尺寸表 Dimension of Input Flange

unit:mm

NO.	ØA1	ØA2	A3	A4	A5	A6	A7	A8
1	19 24	70	51	90	M6	92	133	207
2		80	51	100	M6	92	133	207
3		95	51	115	M6	110	133	207
4		95	51	115	M8	110	133	207
5		110	51	145	M8	130	133	207
6		110	65.5	145	M8	130	147.5	221.5

FA100-2 特性表

減速比 Ratio		15	20	25	30	35	40	50	70	100
額定輸出扭矩 Rated Output Torque	Nm	165	146	160	165	149	146	160	149	141
最大輸出力矩 Max. Output Torque	Nm	3 倍額定輸出扭矩 3 Times of Rated Output Torque								
額定輸入轉速 Rated Input Speed	rpm	3,000								
最大輸入轉速 Max. Input Speed	rpm	5,000								
扭轉剛性 Torsional Rigidity	Nm/arcmin	14								
容許徑向力 Max. Radial Force	N	3,200								
容許軸向力 Max. Axial Force	N	1,600								
使用壽命 Service Life	hr	20,000 (連續運轉壽命 10,000hrs) 20,000 (Continuous operation life 10,000hrs)								
效率 Efficiency	%	≥95%								
使用溫度 Operating Temperature	℃	-25℃~+90℃								
潤滑 Lubrication		全合成潤滑脂 Synthetic Gear Grease								
防護等級 Protection Class		IP 65								
安裝方向 Mounting Position		任意 Any								
噪音值 Noise Level	dB	≤67 dB								
重量 Weight ±2%	Kg									

Bushing 軸套

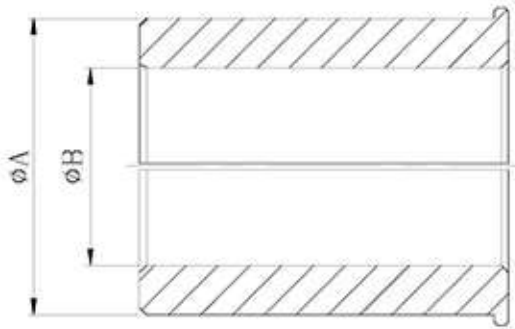

軸套內徑為所使用伺服馬達的輸出軸軸徑。
下表中沒有的情況下需要插入軸套，在您所使用的輸出軸軸徑的近似值中選擇大值。

連接軸_孔徑 ϕA	8	11	14	19	22	24	28	35	38	42	48
軸套_孔徑 ϕB											
6			●								
6.35			●								
8		●	●								
9		●	●								
10			●	●							
11			●								
12			●								
12.7				●							
14				●		●					
16				●		●					
19						●					
22						●					
24											
25											
25.4											
28											
32											
35											
38											
42											